

## Forced draught gas burner

Progressive two-stage or modulating operation



CODE	MODEL
C9531000 (3483270)	RLS 28
C9532000 (3484170)	RLS 38
C9533000 (3484670)	RLS 50
C9533001 (3484670)	RLS 50
(3484675)	RLS 50



<b>1</b>	<b>Information and general instructions</b>	<b>3</b>
1.1	Information about the instruction manual	3
1.1.1	Introduction	3
1.1.2	General dangers	3
1.1.3	Safety precautions	3
1.1.4	Danger: live components	3
1.2	Guarantee and responsibility	4
1.2.1	Owner's responsibility	4
<b>2</b>	<b>Safety and prevention</b>	<b>5</b>
2.1	Introduction	5
2.2	Personnel training	5
<b>3</b>	<b>Technical description of the burner</b>	<b>6</b>
3.1	Technical data	6
3.1.1	Burner models designation:	6
3.1.2	Accessories (optional):	7
3.2	Burner description	7
3.2.1	Packaging - weight - Approximate measurements	8
3.2.2	Max. dimensions - Approximate measurements	8
3.2.3	Standard equipment	8
3.2.4	Firing rates	9
3.2.5	Minimum furnace dimensions	9
<b>4</b>	<b>Installation</b>	<b>10</b>
4.1	Notes on safety for the installation	10
4.2	Handling	10
4.3	Preliminary checks	10
4.4	Boiler plate	11
4.5	Blast tube length	11
4.6	Securing the burner to the boiler	11
4.7	Choice of nozzles for 1st and 2nd stage	12
4.8	Nozzle assembly	13
4.9	Adjustments before first firing (light-oil operation)	14
4.10	Servomotor	14
4.11	Pump	15
4.12	Fuel supply	16
4.13	Hydraulic connections	16
4.14	Pump priming	17
4.15	Burner calibration (light-oil operation)	17
4.16	Gas pressure	18
4.17	Gas piping	18
4.18	Gas train	19
4.19	Adjustments before first firing (gas operation)	19
<b>5</b>	<b>Start-up, calibration and operation of the burner</b>	<b>20</b>
5.1	Notes on safety for the first start-up	20
5.2	Burner starting (gas operation)	20
5.3	Burner firing (gas operation)	20
5.4	Burner calibration (gas operation)	20
5.4.1	High fire output	20
5.4.2	Low fire output	20
5.4.3	Air pressure switch - CO check	21
5.4.4	Low gas pressure switch	21

<b>6</b>	<b>Maintenance</b> .....	<b>22</b>
6.1	Notes on safety for the maintenance .....	22
6.2	Opening the burner. ....	23
6.2.1	To open the burner: .....	23
6.2.2	To close the burner: .....	23
6.3	Hydraulic system layout .....	23
6.3.1	Oil pressure switch .....	23
6.3.2	Combustion checks .....	23
<b>7</b>	<b>Electrical system</b> .....	<b>24</b>
7.1	Electrical wiring .....	24
7.2	Field wiring connections .....	25
7.3	External fuses (see the electrical diagram) .....	25
7.4	Burner firing rates according to air density .....	34
7.5	Flame signal .....	35
7.6	Sequence of operation .....	35
7.7	Firing failure .....	35
7.8	Burner flame goes out during operation .....	35
<b>8</b>	<b>Spare parts</b> .....	<b>38</b>
8.1	Exploded spare parts list .....	38
8.2	Spare parts list .....	39

# 1 Information and general instructions

## 1.1 Information about the instruction manual

### 1.1.1 Introduction

The instruction manual supplied with the burner:

- is an integral and essential part of the product and must not be separated from it; it must therefore be kept carefully for any necessary consultation and must accompany the burner even if it is transferred to another owner or user, or to another system. If the manual is lost or damaged, another copy must be requested from the Technical Assistance Service of the area;
- is designed for use by qualified personnel;
- offers important indications and instructions relating to the installation safety, start-up, use and maintenance of the burner.

#### Symbols used in the manual

In some parts of the manual you will see triangular DANGER signs. Pay great attention to these, as they indicate a situation of potential danger.

### 1.1.2 General dangers

The **dangers** can be of **3 levels**, as indicated below.



Maximum danger level!  
This symbol indicates operations which, if not carried out correctly, **cause** serious injury, death or long-term health risks.



This symbol indicates operations which, if not carried out correctly, **may cause** serious injury, death or long-term health risks.



This symbol indicates operations which, if not carried out correctly, **may cause** damage to the machine and/or injury to people.

### 1.1.3 Safety precautions

Good safety practices must be used when working on burner equipment. The potential energy in the electrical supply, fuel and related equipment must be handled with extreme care to prevent equipment failures, injuries and potential death.



If you smell gas, open window, extinguish any open flames, stay away from electrical switches, evacuate the building and immediately call the gas company.

If this equipment is not installed, operated, operated and maintained in accordance with the manufacturers instructions, this product could expose you to substances in fuel or from fuel combustion which can cause death or serious illness.

Improper servicing of this equipment may create a potential hazard to equipment and operators.

**Servicing must be done by a fully trained and qualified personnel.**

### 1.1.4 Danger: live components



This symbol indicates operations which, if not carried out correctly, lead to electric shocks with lethal consequences.

Other symbols



#### ENVIRONMENTAL PROTECTION

This symbol gives indications for the use of the machine with respect for the environment.

- This symbol indicates a list.

#### Abbreviations used

Ch.	Chapter
Fig.	Figure
Pag.	Page
Sec.	Section
Tab.	Table

#### Delivery of the system and the instruction manual

When the system is delivered, it is important that:

- The instruction manual is supplied to the user by the system manufacturer, with the recommendation to keep it in the room where the heat generator is to be installed.
- The instruction manual shows:
  - the serial number of the burner;

.....

- the address and telephone number of the nearest Assistance Centre;

.....  
 .....  
 .....

- The system supplier carefully informs the user about:
  - the use of the system,
  - any further tests that may be necessary before the system is started up,
  - maintenance and the need to have the system checked at least once a year by the manufacturer or another specialised technician.

To ensure a periodic check, the manufacturer recommends the drawing up of a Maintenance Contract.

## 1.2 Guarantee and responsibility

The manufacturer guarantees its new products from the installation date, in accordance with the regulations in force and/or the sales contract. At the moment of the first start-up, check that the burner is integral and complete.



Failure to observe the information given in this manual, operating negligence, incorrect installation and the carrying out of non authorised modifications will result in the annulment by the manufacturer of the guarantee that it supplies with the burner.

In particular, the rights to the guarantee and the responsibility will no longer be valid, in the event of damage to things or injury to people, if such damage/injury was due to any of the following causes:

- incorrect installation, start-up, use and maintenance of the burner;
- improper, incorrect or unreasonable use of the burner;
- intervention of unqualified personnel;
- carrying out of non authorised modifications on the equipment;
- use of the burner with safety devices that are faulty, incorrectly applied and/or not working;
- installation of untested supplementary components on the burner;
- powering of the burner with unsuitable fuels;
- faults in the fuel power supply system;
- use of the burner even following an error and/or an irregularity;
- repairs and/or overhauls incorrectly carried out;
- modification of the combustion chamber with inserts that prevent the regular development of the flame, as structurally established;
- insufficient and inappropriate surveillance and care of those burner components most subject to wear and tear;
- use of non-original components, including spare parts, kits, accessories and optionals;
- force majeure.

**the manufacturer furthermore declines any and every responsibility for the failure to observe the contents of this manual.**

### 1.2.1 Owner's responsibility

Please pay attention to the Safety Warnings contained within this instruction manual. Keep this manual for your records and provide it to your qualified service agency for use in professionally setting up and maintaining your burner.

Your burner will provide years of efficient operation if it is professionally installed and maintained by a qualified service technician. If at any time the burner does not appear to be operating properly, immediately contact your qualified service agency for consultation.

We recommend annual inspection/service of your gas heating system by a qualified service agency.

Failure to follow these instructions, misuse, or incorrect adjustment of the burner could lead to equipment malfunction and result in asphyxiation, explosion or fire.



If you smell gas:

- Do not touch any electrical items.
- Open all windows.
- Close all gas supply valves.
- Contact your local gas authority immediately.
- Do not store flammable or hazardous materials in the vicinity of fuel burning appliances.
- Improper installation, adjustment, alteration, service or maintenance can cause property damage, personal injury or death.
- Refer to this manual for instructional or additional information.
- Consult a certified installer, service representative or the gas supplier for further assistance.
- Burner shall be installed in accordance with manufacturers requirements as outlined in this manual, local codes and authorities having jurisdiction.

## 2

## Safety and prevention

**2.1 Introduction**

The burners have been designed and built in compliance with current regulations and directives, applying the known technical rules of safety and envisaging all the potential danger situations.

It is necessary, however, to bear in mind that the imprudent and clumsy use of the equipment may lead to situations of death risk for the user or third parties, as well as the damaging of the burner or other items. Inattention, thoughtlessness and excessive confidence often cause accidents; the same applies to tiredness and sleepiness.

It is a good idea to remember the following:

- The burner must only be used as expressly described. Any other use should be considered improper and therefore dangerous.  
In particular:  
it can be applied to boilers operating with water, steam, diathermic oil, and to other users expressly named by the manufacturer;  
the type and pressure of the fuel, the voltage and frequency of the electrical power supply, the minimum and maximum deliveries for which the burner has been regulated, the pressurisation of the combustion chamber, the dimensions of the combustion chamber and the room temperature must all be within the values indicated in the instruction manual.
- Modification of the burner to alter its performance and destinations is not allowed.
- The burner must be used in exemplary technical safety conditions. Any disturbances that could compromise safety must be quickly eliminated.
- Opening or tampering with the burner components is not allowed, apart from the parts requiring maintenance.
- Only those parts envisaged by the manufacturer can be replaced.

**2.2 Personnel training**

The user is the person, body or company that has acquired the machine and intends to use it for the specific purpose. He is responsible for the machine and for the training of the people working around it.

The user:

- Undertakes to entrust the machine exclusively to suitably trained and qualified personnel.
- Must take all the measures necessary to prevent unauthorised people gaining access to the machine.
- Undertakes to inform his personnel in a suitable way about the application and observance of the safety instructions. With that aim, he undertakes to ensure that everyone knows the use and safety instructions for his own duties.
- Must inform the manufacturer if faults or malfunctioning of the accident prevention systems are noticed, along with any presumed danger situation.
- Personnel must always use the personal protective equipment envisaged by legislation and follow the indications given in this manual.
- Personnel must follow all the danger and caution indications shown on the machine.
- Personnel must not carry out, on their own initiative, operations or interventions that are not within their province.
- Personnel are obliged to inform their superiors of every problem or dangerous situation that may arise.
- The assembly of parts of other makes, or any modifications, can alter the characteristics of the machine and hence compromise operating safety. The manufacturer therefore declines any and all responsibility for any damage that may be caused by the use of non-original parts.

## 3 Technical description of the burner

### 3.1 Technical data

MODEL			RLS 28	RLS 38	RLS 50	RLS 50
Output (1) Delivery (1)	2nd stage	MBtu/hr(4) kW GPH	616 - 1232 181 - 361 4.4 - 8.8	882 - 1666 258 - 488 6.3 - 11.9	1092 - 2198 320 - 644 7.8 - 15.7	1092 - 2198 320 - 644 7.8 - 15.7
	min. 1st stage	MBtu/hr(4) kW GPH	378 111 2.7	434 127 3.1	546 160 3.9	546 160 3.9
Fuel			#2 Fuel oil Natural gas / Propane gas			
Gas pressure at maximum delivery (2), Gas: Natural gas		" WC	4.33	5.11	5.51	5.51
Operation			low-high			
Nozzles		number	2			
Ambient temperature		°F	32 - 104 (0 - 40 °C)			
Combustion air temperature		°F max	140 (60 °C)			
Main power supply (+/- 10%)		V/Ph/Hz	120/1/60		208-230/460/ 575/3/60	120/1/60
Electric motors		rpm	3400			
Fan motor		V	120	120	208 - 230 / 460 / 575	120 - 230
		W - HP	370 - 0.5	370 - 0.5	550 - 0.75	550 - 0.75
		A	5.2	5.2	3.2 - 1.6 - 1.3	9.8 - 4.9
Fan motor capacitor		µF	45	45	n/a	40
		V	120			
Pump motor		W - HP	90 - 0.12			
		A	0,8			
		µF	12,5			
Ignition transformer	Oil	V1 - V2 I1 - I2	120 V - 2 x 5 kV 3.7 A - 35 mA			
	Gas	V1 - V2 I1 - I2	120 V - 1 x 7 kV 1.6 A - 23 mA			
Pump	Delivery (at 174 PSI)	GPH	21.5			
	Pressure range	PSI	58 - 261			
	Fuel temperature	° F max	140 (60 °C)			
Electrical power consumption		W max	760	760	910	860
Electrical protection			NEMA 1			
Noise Levels (3)		dBA	68	70	72	72

Tab. A

- (1) Reference conditions: Ambient temperature 68 °F (20°C) - Barometric pressure 394" WC - Altitude 329 ft.
- (2) Pressure at test point 7) (Fig. 1, page 7) with zero pressure in the combustion chamber and maximum burner output.
- (3) Sound pressure measured in manufacturer's combustion laboratory, with burner operating on test boiler and at maximum rated output.
- (4) Equivalent Btu values based on 1 USGPH = 140,000 Btu/hr.

#### 3.1.1 Burner models designation:

Model	Code	Voltage	Flame safeguard
RLS 28	C9531000 (3483270)	120/1/60	Burner mounted
RLS 38	C9532000 (3484170)	120/1/60	Burner mounted
RLS 50	C9533000 (3484670)	208-230/460/3/60	Burner mounted
	C9533001 (3484670)	575/3/60	Burner mounted
	(3484675)	120/1/60	Burner mounted

Tab. B

## 3.1.2 Accessories (optional):

- **Kit for lengthening the combustion head**

L = Standard length

L1 = Length obtainable with the kit

COD. 3010264 L = 7 1/2" L1 = 12 27/32"

COD. 3010265 L = 7 29/32" L1 = 13 7/32"

COD. 3010266 L = 8 1/2" L1 = 13 13/16"

- RLS 28

- RLS 38

- RLS 50

- **Kit for LPG operation** - Code **3010304**: The kit allows the RLS 28-38-50 burners to operate on LPG.

- **Gas train according to UL Standards**: see page 18.

**NOTE:**

The installer is responsible for the supply and installation of any required safety device(s) not indicated in this manual.

## 3.2 Burner description

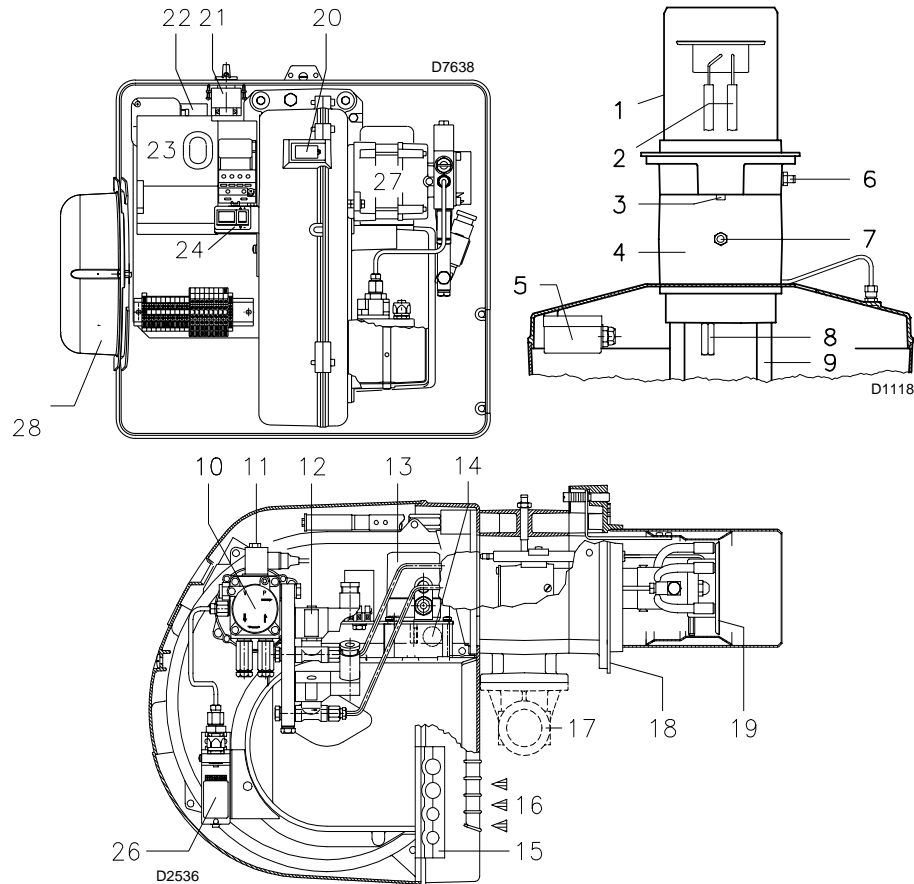

**Fig. 1**

- |  |  |
|--|--|
| <ul style="list-style-type: none"> <li>1 Combustion head</li> <li>2 Ignition electrodes</li> <li>3 Screw for combustion head adjustment</li> <li>4 Sleeve</li> <li>5 Low air pressure switch (differential operating type)</li> <li>6 Air pressure test point</li> <li>7 Gas pressure test point and head fixing screw</li> <li>8 Screw securing fan to sleeve</li> <li>9 Slide bars for opening the burner and inspecting the combustion head</li> <li>10 Pump</li> <li>11 Safety solenoid valve</li> <li>12 Low and high fire oil valves</li> <li>13 Servomotor</li> <li>14 UV scanner</li> <li>15 Plate with four hole knock-outs for flexible hoses and electrical cable routing.</li> <li>16 Air inlet to fan</li> <li>17 Gas input connection</li> <li>18 Boiler mounting flange</li> <li>19 Flame stability disk</li> <li>20 Flame inspection disk</li> <li>21 Oil / gas selector switch</li> </ul> | <ul style="list-style-type: none"> <li>22 Fan motor contactor and thermal overload with reset button (RLS 50 three-phase)</li> <li>23 Flame safeguard with lock-out pilot light and lock-out reset button</li> <li>24 Power switch for different operations: automatic - manual - off<br/>Button for:<br/>power increase - power reduction</li> <li>25 Burner terminal strip</li> <li>26 Low oil pressure switch</li> <li>27 Pump motor</li> <li>28 Protection (for RLS 50 single-phase burner)</li> </ul> <p>Two types of burner failure may occur:</p> <ul style="list-style-type: none"> <li>• <b>Flame safeguard lock-out:</b><br/>if the flame relay 23) (Fig. 1) pushbutton lights up, it indicates that the burner is in lock-out.<br/>To reset, press the pushbutton.</li> <li>• <b>Motor trip</b> (RLS 50 three-phase):<br/>Release by pressing the pushbutton on the thermal overload 22)(A).</li> </ul> |
|--|--|

### 3.2.1 Packaging - weight - Approximate measurements

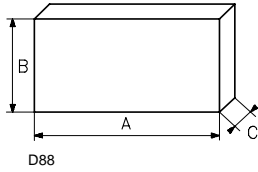

**Fig. 2**

- The burners are shipped in cardboard boxes with the maximum dimensions shown in (Tab. C).
- The weight of the burner complete with packaging is indicated in (Tab. C).

inch	A	B	C	lbs
RLS 28	39 <sup>31</sup> / <sub>32</sub> "	24 <sup>13</sup> / <sub>16</sub> "	19 <sup>11</sup> / <sub>16</sub> "	95
RLS 38	39 <sup>31</sup> / <sub>32</sub> "	24 <sup>13</sup> / <sub>16</sub> "	19 <sup>11</sup> / <sub>16</sub> "	99
RLS 50 three-phase	39 <sup>31</sup> / <sub>32</sub> "	24 <sup>13</sup> / <sub>16</sub> "	19 <sup>11</sup> / <sub>16</sub> "	101
RLS 50 single-phase	39 <sup>31</sup> / <sub>32</sub> "	24 <sup>13</sup> / <sub>16</sub> "	21 <sup>11</sup> / <sub>16</sub> "	103

**Tab. C**

### 3.2.2 Max. dimensions - Approximate measurements

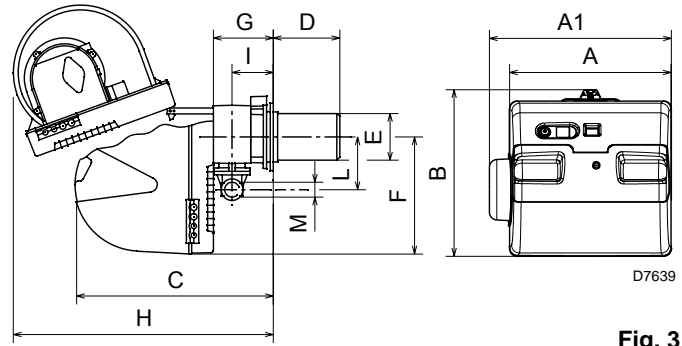

**Fig. 3**

The maximum dimensions of the burners are given in (Fig. 3). Note that if you need to examine the combustion head, the burner must be pulled backward on the slide bars and turned upward. The maximum dimension of the burner, without the cover, when open is given by measurement H.

inch	A	A1	B	C	D	E	F	G	H	I	L	M
RLS 28	18 <sup>23</sup> / <sub>32</sub> "	-	18 <sup>21</sup> / <sub>32</sub> "	22 <sup>13</sup> / <sub>16</sub> "	7 <sup>1</sup> / <sub>2</sub> "	5 <sup>1</sup> / <sub>2</sub> "	13 <sup>27</sup> / <sub>32</sub> "	6 <sup>7</sup> / <sub>16</sub> "	31 <sup>7</sup> / <sub>8</sub> "	4 <sup>1</sup> / <sub>4</sub> "	6 <sup>5</sup> / <sub>8</sub> "	1 <sup>1</sup> / <sub>2</sub> "
RLS 38	18 <sup>23</sup> / <sub>32</sub> "	-	18 <sup>21</sup> / <sub>32</sub> "	22 <sup>13</sup> / <sub>16</sub> "	7 <sup>29</sup> / <sub>32</sub> "	5 <sup>31</sup> / <sub>32</sub> "	13 <sup>27</sup> / <sub>32</sub> "	6 <sup>7</sup> / <sub>16</sub> "	31 <sup>7</sup> / <sub>8</sub> "	4 <sup>1</sup> / <sub>4</sub> "	6 <sup>5</sup> / <sub>8</sub> "	1 <sup>1</sup> / <sub>2</sub> "
RLS 50 three-phase	18 <sup>23</sup> / <sub>32</sub> "	-	18 <sup>21</sup> / <sub>32</sub> "	22 <sup>13</sup> / <sub>16</sub> "	8 <sup>1</sup> / <sub>2</sub> "	5 <sup>31</sup> / <sub>32</sub> "	13 <sup>27</sup> / <sub>32</sub> "	6 <sup>7</sup> / <sub>16</sub> "	31 <sup>7</sup> / <sub>8</sub> "	4 <sup>1</sup> / <sub>4</sub> "	6 <sup>5</sup> / <sub>8</sub> "	1 <sup>1</sup> / <sub>2</sub> "
RLS 50 single-phase	-	21 <sup>3</sup> / <sub>16</sub> "	18 <sup>21</sup> / <sub>32</sub> "	22 <sup>13</sup> / <sub>16</sub> "	8 <sup>1</sup> / <sub>2</sub> "	5 <sup>31</sup> / <sub>32</sub> "	13 <sup>27</sup> / <sub>32</sub> "	6 <sup>7</sup> / <sub>16</sub> "	31 <sup>7</sup> / <sub>8</sub> "	4 <sup>1</sup> / <sub>4</sub> "	6 <sup>5</sup> / <sub>8</sub> "	1 <sup>1</sup> / <sub>2</sub> "

**Tab. D**

### 3.2.3 Standard equipment

- 1 - Gas train flange
- 1 - Flange gasket
- 4 - Flange fixing screws
- 4 - Screws to secure the burner flange to the boiler: 3/8 W x 1"
- 1 - Adaptor G 1/8" / 1/8" NPT
- 1 - Instruction booklet
- 1 - Spare parts list

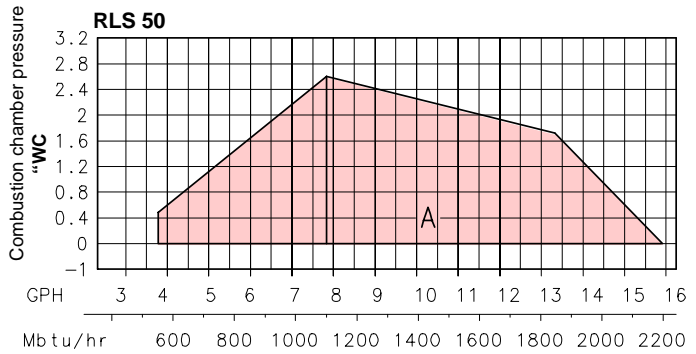
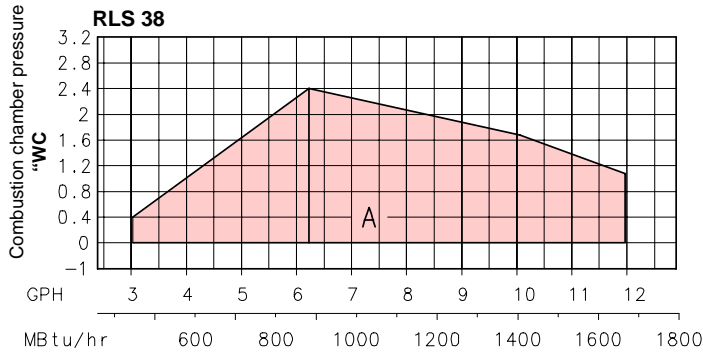
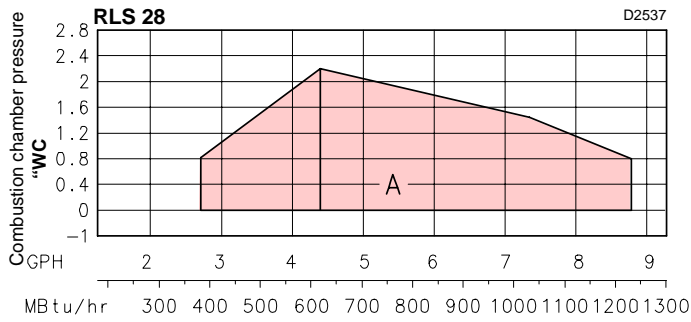

**Fig. 4**

### 3.2.4 Firing rates

The RLS 28 - 38 - 50 Model burners can work in two ways: low and high fire.

**MAXIMUM OUTPUT** must be selected in area A.

**MINIMUM OUTPUT** must not be lower than the minimum limit shown in the diagram:

RLS 28 = 378 MBtu/hr = 2.7 GPH

RLS 38 = 434 MBtu/hr = 3.1 GPH

RLS 50 = 546 MBtu/hr = 3.9 GPH



The firing rate area values have been obtained considering an ambient temperature of 68 °F (20°C), and an atmospheric pressure of 394" WC and with the combustion head adjusted as shown on page 14.

**NOTE:**

The **FIRING RATE** areas given in (Fig. 4) have been reduced by **10%** with respect to the maximum range that can be reached.

Consult on page 34 for operation at different ambient temperatures and/or altitudes.

### 3.2.5 Minimum furnace dimensions

The firing rates were set in relation to certified test boilers.

Figure (Fig. 5) indicates the diameter and length of the test combustion chamber.

**Example:**

output 1388 MBtu/hr:

diameter 20 inch - length 4.9 ft.

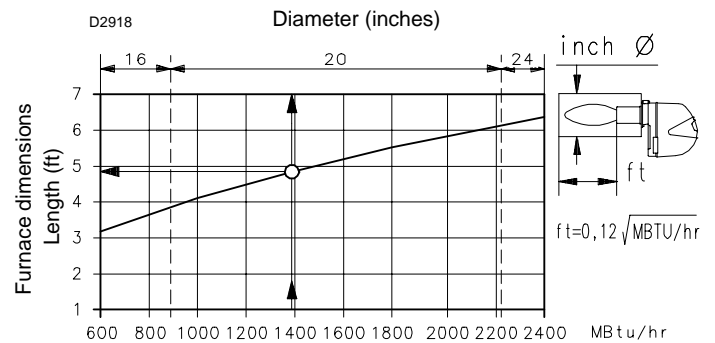

**Fig. 5**

**4 Installation****4.1 Notes on safety for the installation**

After carefully cleaning all around the area where the burner will be installed, and arranging the correct lighting of the environment, proceed with the installation operations.



All the installation, maintenance and disassembly operations must be carried out with the electricity supply disconnected.



The installation of the burner must be carried out by qualified personnel, as indicated in this manual and in compliance with the standards and regulations of the laws in force.

**4.2 Handling**

The packaging of the burner includes a wooden platform, so it is possible to move the burner (still packaged) with a transpallet truck or fork lift truck.

With regard to the transport in the obligatory passages, refer to the overall dimensions shown in Fig. 2, page 8.



The handling operations for the burner can be highly dangerous if not carried out with the greatest attention: keep any unauthorised people at a distance; check the integrity and suitability of the available means of handling.

Check also that the area in which you are working is empty and that there is an adequate escape area (i.e. a free, safe area to which you can quickly move if the burner should fall).

During the handling, keep the load at not more than 10" from the ground.



After positioning the burner near the installation point, correctly dispose of all residual packaging, separating the various types of material. Before proceeding with the installation operations, carefully clean all around the area where the burner will be installed.

**4.3 Preliminary checks****Checking the consignment**

After removing all the packaging, check the integrity of the contents. In the event of doubt, do not use the burner; contact the supplier.



The packaging elements (wooden cage or cardboard box, nails, clips, plastic bags, etc.) must not be abandoned as they are potential sources of danger and pollution; they should be collected and disposed of in the appropriate places.



The output of the burner must be within the boiler's firing rate;



A burner label that has been tampered with, removed or is missing, along with anything else that prevents the definite identification of the burner makes any installation or maintenance work difficult.

#### 4.4 Boiler plate

Drill the combustion chamber mounting plate as shown in (Fig. 6). The position of the threaded holes can be marked using the head gasket supplied with the burner.

inch	A	B	C
RLS 28	6 <sup>9</sup> / <sub>32</sub> "	8 <sup>13</sup> / <sub>16</sub> "	<sup>3</sup> / <sub>8</sub> W
RLS 38	6 <sup>9</sup> / <sub>32</sub> "	8 <sup>13</sup> / <sub>16</sub> "	<sup>3</sup> / <sub>8</sub> W
RLS 50	6 <sup>9</sup> / <sub>32</sub> "	8 <sup>13</sup> / <sub>16</sub> "	<sup>3</sup> / <sub>8</sub> W

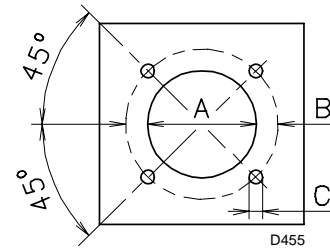

Fig. 6

#### 4.5 Blast tube length

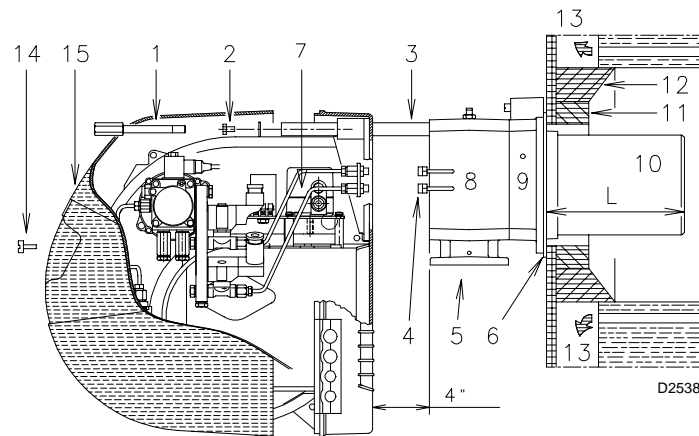

Fig. 7

The length of the blast tube must be selected according to the indications provided by the manufacturer of the boiler, and it must be greater than the thickness of the boiler door complete with its insulation. The range of lengths available, L (inch), is as follows

Blast tube 10):	RLS 28	RLS 38	RLS 50
• short	71/2"	729/32"	81/2"
• long	1227/32"	137/32"	1313/16"

For boilers with front flue passes 13) or flame inversion chambers, protective insulation 11) must be inserted between the boiler refractory 12) and the blast tube 10).

This protective insulation must not compromise the extraction of the blast tube.

For boilers having a water-cooled front the insulation 11)-12) (Fig. 7) is not required unless it is required by the boiler manufacturer.

#### 4.6 Securing the burner to the boiler

Detach the combustion head from the burner, (Fig. 7):

- disconnect the oil pipes by unscrewing the two connectors 4).
- remove screw 14) and withdraw the cover 15).
- remove the screws 2) from the slide bars 3).
- remove screw 1) and pull the burner back on slide bars 3) by about 4".

Disconnect the electrode wires and then pull the burner completely off the slide bars, after removing the split pin from the slide bar 3).

Secure the flange 9) (Fig. 7) to the boiler plate, inserting the gasket 6) (Fig. 7). Use the 4 screws, also supplied with the unit, after first protecting the thread with an anti-locking product.

The seal between burner and boiler must be airtight.

## 4.7 Choice of nozzles for 1st and 2nd stage

The burner complies with the emission requirements of the UL 296 standard.

In order to guarantee that emissions do not vary, recommended and/or alternative nozzles specified by the manufacturer in the Instruction and warning booklet should be used.



**It is advisable to replace nozzles every year during regular maintenance operations.**



**The use of nozzles other than those specified by the manufacturer and inadequate regular maintenance may result into emission limits non-conforming to the values set forth by the regulations in force, and in extremely serious cases, into potential hazards to people and objects.**

**The manufacturing company shall not be liable for any such damage arising from nonobservance of the requirements contained in this manual.**

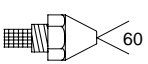

NOZZLE GPH	GPH			174 PSI	MBTU/h
	145 PSI	174 PSI	203 PSI		
RLS 28	2.00	2.47	2.72	2.95	381
	2.25	2.75	3.04	3.33	426
	2.50	3.07	3.39	3.68	475
	3.00	3.68	4.07	4.42	570
	3.50	4.32	4.74	5.16	664
RLS 38	2.50	3.07	3.39	3.68	475
	3.00	3.68	4.07	4.42	570
	3.50	4.32	4.74	5.16	664
	4.00	4.93	5.44	5.89	762
	4.50	5.54	6.12	6.63	857
RLS 50	5.00	6.15	6.79	7.36	951
	3.00	3.68	4.07	4.42	570
	3.50	4.32	4.74	5.16	664
	4.00	4.93	5.44	5.89	762
	4.50	5.54	6.12	6.63	857
	5.00	6.15	6.79	7.36	951
	5.50	6.76	7.46	8.10	1044
6.00	7.40	8.17	8.87	1144	

**Tab. E**

Both nozzles must be chosen from among those listed in (Tab. E).

The first nozzle determines the delivery of the burner at low fire.

The second nozzle works together with the 1st nozzle to determine the delivery of the burner at high fire.

The deliveries at low and high fire must be contained within the value range indicated on page 6.

Use nozzles with a 60° spray angle at the recommended pressure of 174 PSI. The two nozzles usually have equal deliveries.

**Example with the RLS 28 Model**

Boiler output = 921 MBtu/hr @ efficiency 80 %

Output required by the burner =

$$921 / 0.8 = 1151 \text{ MBtu/hr}$$

$$1151 / 2 = 576 \text{ MBtu/hr (4.0 USGPH) per nozzle}$$

therefore, two equal, 60°, 174 PSI nozzles are required:

$$1^\circ = 4.00 \text{ GPH with } 2^\circ = 4.00 \text{ GPH,}$$

or the following two different nozzles:

$$1^\circ = 4.50 \text{ GPH with } 2^\circ = 3.50 \text{ GPH,}$$

or:

$$1^\circ = 3.50 \text{ GPH with } 2^\circ = 4.50 \text{ GPH.}$$

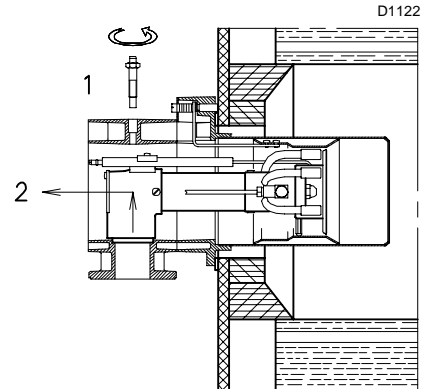

**Fig. 8**

### 4.8 Nozzle assembly

Remove screw 1) (Fig. 8, page 12) and extract the internal part 2) (Fig. 8, page 12) Install two nozzles with the box wrench 1) (Fig. 9), after having removed the plastic plugs 2) (Fig. 9), fitting the wrench through the central hole in the flame stability disk or loosen screws 1) (Fig. 10), remove disk 2) (Fig. 10) and replace the nozzles using the wrench 3) (Fig. 10).

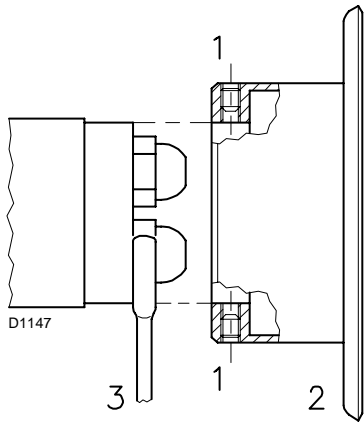
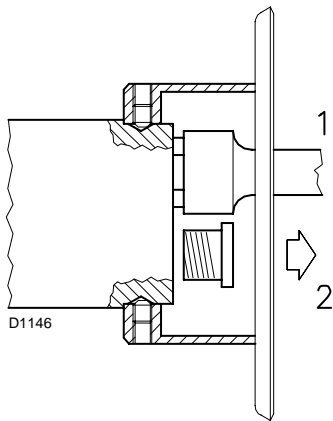

Fig. 9

Fig. 10



WARNING

- Do not use any sealing products such as gaskets, sealing compound, or tape.
- Be careful to avoid damaging the nozzle sealing seat.
- The nozzles must be screwed into place tightly but carefully.

The nozzle for low fire operation is the one underneath the firing electrodes (Fig. 11).

Make sure that the electrodes are positioned as shown in (Fig. 11).

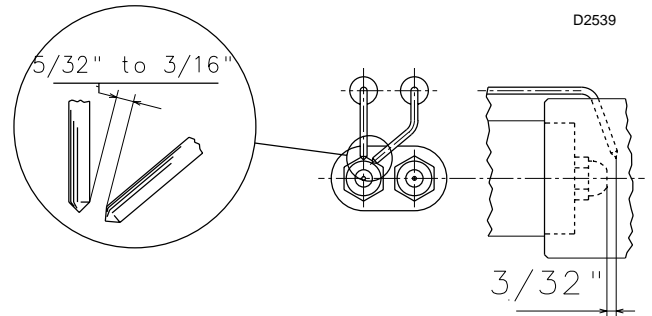

D2539

Fig. 11

Refit the burner 4) (Fig. 12) to the slide bars 3) at approximately 4" from the sleeve 5) - burner positioned as shown in (Fig. 7, page 11) - insert the ignition electrode cables and then slide the burner up to the sleeve so that it is positioned as shown in (Fig. 12).

Refit screws 2) (Fig. 12) on slide bars 3).

Secure the burner to the sleeve by tightening screw 1) and then refit the split pin into one of two slide bars 3).

Connect the oil pipes again by screwing on the two connectors 4) (Fig. 7, page 11).

**NOTE:**

**When fitting the burner on the two slide bars, it is advisable to gently draw out the high tension cables until they are slightly stretched.**

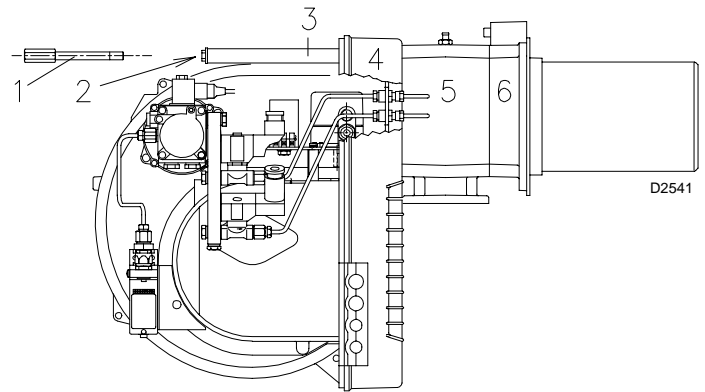

D2541

Fig. 12

**4.9 Adjustments before first firing (light-oil operation)**

• **Combustion head setting**

The setting of the combustion head depends exclusively on the delivery of the burner at high fire. Turn screw 5) (Fig. 13) until the notch shown in diagram (Fig. 14) is level with the front surface of flange 6) (Fig. 13).

• **Example burner RLS 38:**

High fire burner delivery = 9.6 GPH.

If diagram (Fig. 14) is consulted it is clear that for this delivery, the combustion head must be adjusted using notch 4, as shown in (Fig. 13).

• **Pump adjustment**

No settings are required for the pump, which is set to 174 PSI by the manufacturer. This pressure must be checked and adjusted (if required) after the burner has been ignited. The only operation required in this phase is the application of a pressure gauge on the appropriate pump connection.

• **Fan damper adjustment**

The first time the burner is fired leave the factory setting unchanged for both low and high fire operation.

SETTING THE COMBUSTION HEAD

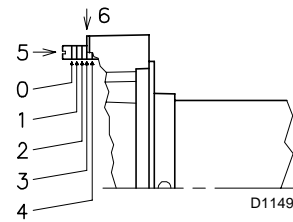

**Fig. 13**

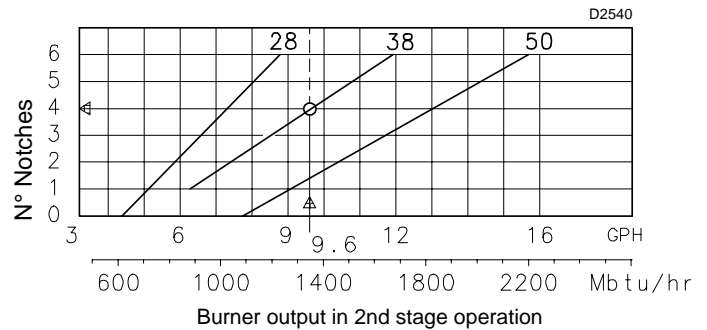

**Fig. 14**

**4.10 Servomotor**

The servomotor adjusts the air damper.

The servomotor rotates through 90° in 25 seconds.

Do not alter (for the time-being) the factory setting.

**Blue cam**

Sets the position of the air damper during low fire operation.

**Red cam**

Sets the position of the air damper during high fire operation.

**Orange cam**

Establishes when the high fire gas or fuel oil valve opens.

It must always operate (just) before the red cam and after the blue cam.

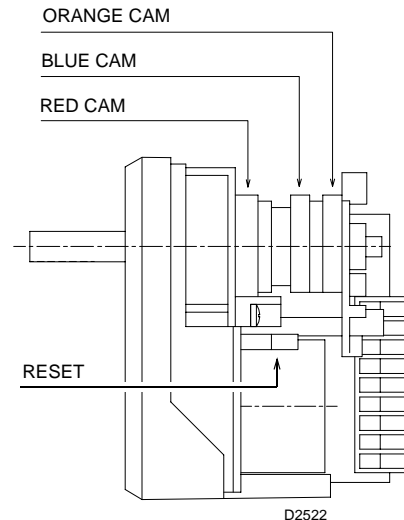

**Fig. 15**

4.11 Pump

- 1 Suction 1/4" NPT
- 2 Return 1/4" NPT
- 3 Pressure gauge attachment G 1/8"
- 4 Vacuum gauge attachment G 1/8"
- 5 Pressure regulator
- A Min. delivery rate at 174 PSI pressure
- B Delivery pressure range
- C Max. suction pressure
- D Viscosity range
- E Max fuel oil temperature
- F Max. suction and return pressure
- G Pressure calibration in the factory
- H Filter mesh width

PUMP  
SUNTEC AL 65

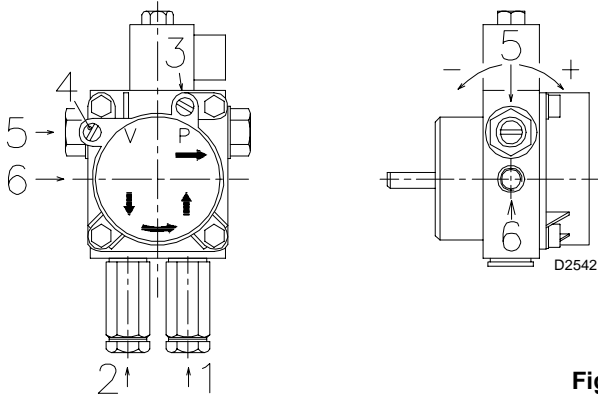

Fig. 16

AL 65

A	GPH	21.5
B	PSI	58 - 261
C	"Hg	13
D	cSt	2 - 12
E	°F - °C	140 - 60
F	PSI	29
G	PSI	174
H	inch	0.006

Tab. F

**4.12 Fuel supply**

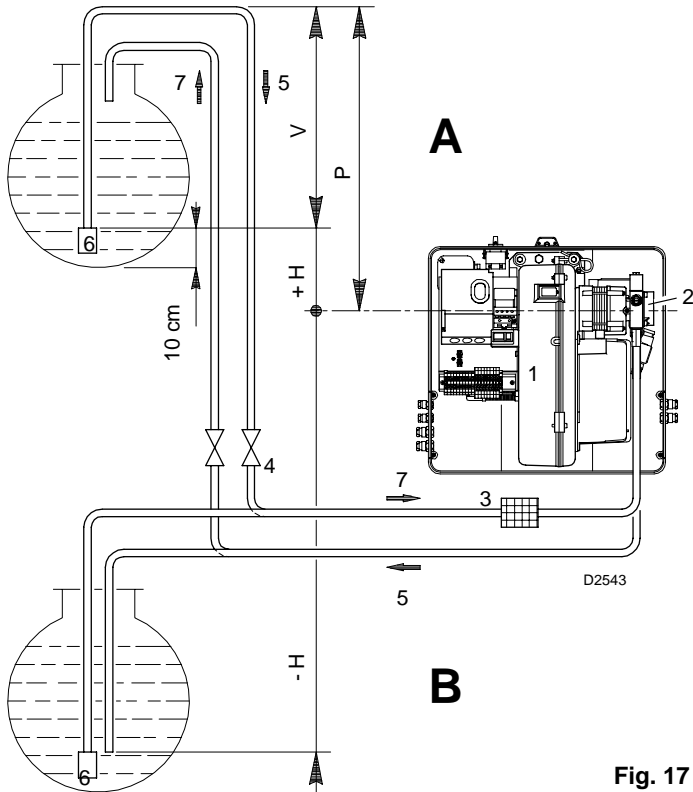

**Fig. 17**

The burner is equipped with a self-priming pump which is capable of feeding itself within the limits listed in the table at the side.

**The tank higher than the burner A**

The distance "P" must not exceed 33 ft in order to avoid subjecting the pump's seal to excessive strain; the distance "V" must not exceed 13 ft in order to permit pump self-priming even when the tank is almost completely empty.

**The tank lower than the burner B**

Pump suction values higher than 13 "Hg must not be exceeded because at higher levels gas is released from the fuel, the pump starts making noise and its working life-span decreases.

It is good practice to ensure that the return and suction lines enter the burner from the same height; in this way it will be more improbable that the suction line fails to prime or stops priming.

+ H - H ft	L ft		
	Ø inch		
	5/16"	3/8"	1/2"
+ 13	115	296	500
+ 10	99	263	500
+ 6.6	86	227	500
+ 3.3	69	194	428
+ 1.6	63	174	391
0	56	158	355
- 1.5	49	141	319
- 3.3	43	122	283
- 6.6	30	89	211
- 10	13	53	138
- 13	-	20	66

**Tab. G**

**Key**

- H = Pump/Foot valve height difference
- L = Piping length
- Ø = Inside pipe diameter
- 1 = Burner
- 2 = Pump
- 3 = Filter
- 4 = Manual on/off valve
- 5 = Suction line
- 6 = Foot valve
- 7 = Return line

**4.13 Hydraulic connections**

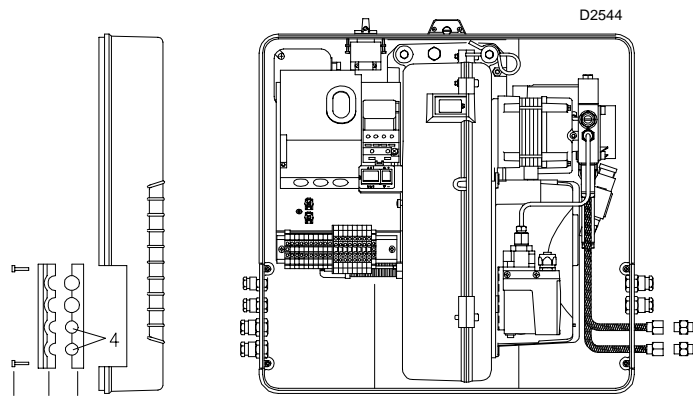

**Fig. 18**

The pumps are equipped with a by-pass that connects return line and suction line. The pumps are installed on the burner with the by-pass closed by screw 6), see diagram Fig. 32, page 23.

It is therefore necessary to connect both hoses to the pump.

**The pump seal will be damaged immediately** if it is run with the return line closed and the by-pass screw inserted.

Remove the plugs from the suction and return connections of the pump.

Insert the hose connectors into the connections and screw them down.

Take care that the hoses are not stretched or twisted during installation.

Route the hoses through the holes in the plate, preferably using those on the right side, (Fig. 18): unscrew the screws 1), now divide the insert piece into its two parts 2) and 3) and remove the thin plug blocking the two passages 4). Install the hoses where they cannot be stepped on or come into contact with hot surfaces of the boiler and where they do not hamper the opening of the burner.

Now connect the other end of the hoses to the suction and return lines.

#### 4.14 Pump priming

- Before starting the burner, make sure that the tank return line is not clogged. Obstructions in the line could cause the pump seal located on the pump shaft to break. (The pump leaves the factory with the by-pass closed).
- Also check to make sure that the valves located on the suction line are open and that there is sufficient fuel in the tank.
- For self-priming to take place, one of the screws 3) of the pump, see Fig. 16, page 15, must be loosened in order to bleed off the air contained in the suction line
- Start the burner by closing the control circuit, with switch 1) (Fig. 19) in the "MAN" position and with switch 21) (Fig. 1, page 7) in the "OIL" position.
- The pump is primed when the fuel oil starts coming out of the screw 3) (Fig. 16, page 15). Stop the burner: switch 1) (Fig. 19) set to "OFF" and tighten the screw 3).

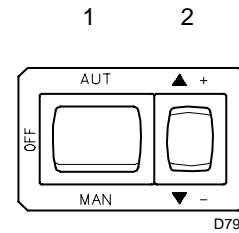

Fig. 19

The time required for this operation depends upon the diameter and length of the suction tubing. If the pump fails to prime at the first starting of the burner and the burner locks out, reset the burner, and then repeat the starting operation.

Do not illuminate the UV scanner cell or the burner will lock out.

#### 4.15 Burner calibration (light-oil operation)

##### NOTE:

It is advisable to first set the burner for operation on oil and then for gas.



Turn burner off prior to switching fuels

##### • FIRING

Set switch 1) (Fig. 19) to "MAN".

During the first firing, and the change from low to high fire, there is a momentary lowering of the fuel pressure caused by the filling of the high fire nozzle tubing. This lowering of the fuel pressure can cause the burner to lock-out.

##### • OPERATION

The optimum calibration of the burner requires an analysis of the flue gases at the boiler outlet and adjustments at the following points:

##### Low and high fire nozzles

See the information listed on page 12.

##### Combustion head

The adjustment of the combustion head already carried out (page 19) need not be altered unless the high fire input of the burner is changed.

##### Pump pressure

174 PSI: this is the pressure calibrated in the factory which is usually sufficient for most purposes. Sometimes, this pressure must be adjusted to:

145 PSI in order to reduce fuel delivery. This adjustment is possible only if the surrounding temperature remains above 0°C;

203 PSI in order to increase fuel delivery or to ensure firings even at temperatures of less than 0°C.

In order to adjust pump pressure, use the screw 5) (Fig. 16, page 15).

##### Low fire fan air damper

Keep the burner operating at low fire. The fan air damper is adjusted by moving the blue cam of the servomotor, see page 14.

##### High fire fan air damper

Press switch 2) (Fig. 19) "increase output" and keep it pressed until the high fire position. The fan air damper is adjusted by moving the red cam of the servomotor, see page 14.

**4.16 Gas pressure**

The adjacent tables are used to calculate manifold pressure taking into account combustion chamber pressure.

Gas manifold pressure measured at test point 1) (Fig. 20), with:

- Combustion chamber at 0" WC
- Burner operating at high fire
- Natural gas

Calculate the approximate high fire output of the burner as follows: subtract the combustion chamber pressure from the gas pressure measured at test point 1) (Fig. 20).

Find the nearest pressure value to your result in the table for the burner in question.

Read off the corresponding output on the left.

**Example - RLS 28**

- High fire operation
  - Natural gas
  - Gas pressure at test point 1) (Fig. 20) = 3.66" WC
  - Pressure in combustion chamber = 0.79" WC
- 3.66 - 0.79 = 2.87" WC

A high fire output of 796 MBtu/hr shown in table RLS 28 corresponds to 2.87" WC pressure, natural gas.

This value serves as a rough guide, the effective delivery must be measured at the gas meter.

RLS 28	MBtu/hr	Δp (" WC)	Natural gas
	616		2.56
	700		2.68
	796		2.87
	890		3.15
	985		3.43
	1079		3.78
	1174		4.09
	1232		4.33

**Tab. H**

RLS 38	MBtu/hr	Δp (" WC)	Natural gas
	882		3.46
	985		3.58
	1098		3.70
	1212		3.86
	1325		4.09
	1440		4.37
	1553		4.65
	1666		5.11

**Tab. I**

RLS 50	MBtu/hr	Δp (" WC)	Natural gas
	1092		3.94
	1250		4.02
	1401		4.13
	1553		4.25
	1704		4.45
	1856		4.61
	2007		5.00
	2198		5.51

**Tab. J**

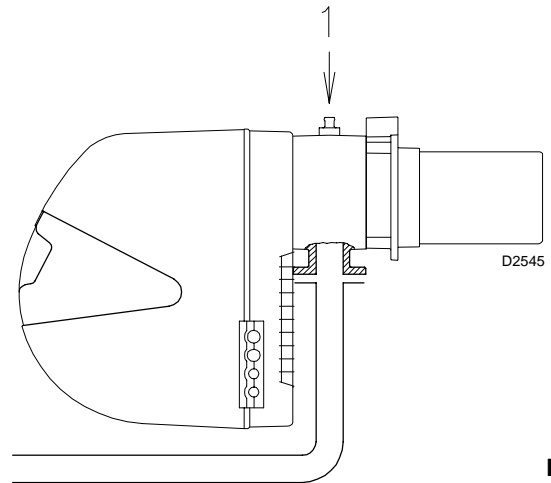

**Fig. 20**

**4.17 Gas piping**

- The gas train must be connected to the gas attachment 1) (Fig. 21), using flange 2), gasket 3) and screws 4) supplied with the burner.
- The gas train can enter the burner from the right or left side, depending on which is the most convenient, see (Fig. 21).
- Gas solenoid 6) (Fig. 22, page 19) must be as close as possible to the burner to ensure gas reaches the combustion head within the safety time period.
- Make sure that the pressure governor calibration range (colour of the spring) comprises the pressure required by the burner.

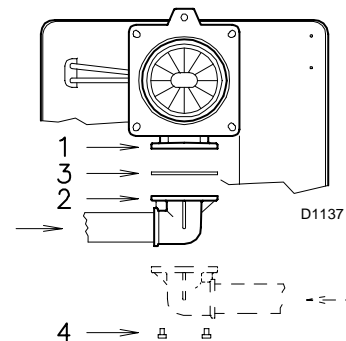

**Fig. 21**

### 4.18 Gas train

It must be type-approved according to UL Standards and is supplied separately from the burner.

**NOTE:**

See the accompanying instructions for the adjustment of the gas train.

**Key to layout**

- 1 Gas input pipe
- 2 Manual valve
- 3 Pressure regulator
- 4 Low gas pressure switch
- 5 Safety solenoid VS
- 6 2nd safety shut-off valve
- 7 Standard issue burner gasket with flange
- 8 Burner

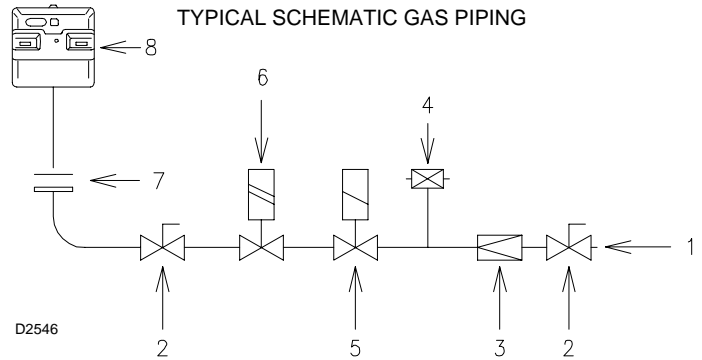

Fig. 22

### 4.19 Adjustments before first firing (gas operation)

Adjustment of the combustion head has been illustrated on page 14.

In addition, the following adjustments must also be made:

- open manual valves down stream and up stream from the gas train.
- Adjust the minimum gas pressure switch to the start of the scale (Fig. 23).

LOW GAS PRESSURE SWITCH

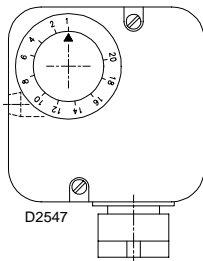

AIR PRESSURE SWITCH

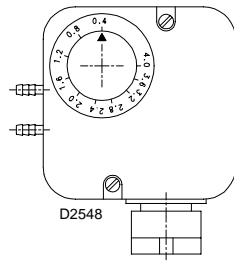

Fig. 23

- Adjust the air pressure switch to the zero position of the scale (Fig. 24).

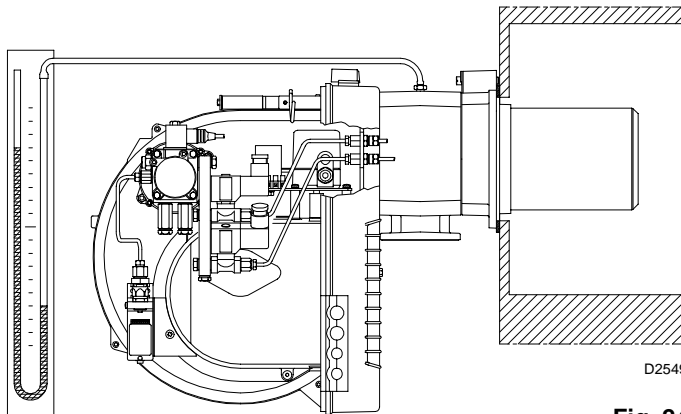

Fig. 24

- Purge the air from the gas line.  
Fit a U-type manometer (Fig. 25) to the gas pressure test point on the sleeve.  
The manometer readings are used to calculate the high fire burner firing rate using the tables on page 18.

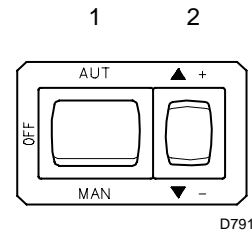

Fig. 25

Before starting up the burner it is good practice to adjust the gas train so that ignition takes place in conditions of maximum safety, i.e. with gas delivery at the minimum.

## 5

## Start-up, calibration and operation of the burner

### 5.1 Notes on safety for the first start-up



The first start-up of the burner must be carried out by qualified personnel, as indicated in this manual and in compliance with the standards and regulations of the laws in force.



Check the correct working of the adjustment, command and safety devices.

### 5.2 Burner starting (gas operation)

**NOTE:**  
it is advisable to first set the burner to operate on oil and then on gas.



Turn burner off prior to switching fuels

Close the control circuit and set switch 1) (Fig. 26) to "MAN" position.

### 5.3 Burner firing (gas operation)

Having completed the checks indicated in the previous heading, the burner should fire. If the motor starts but the flame does not appear and the flame relay goes into lock-out, reset and wait for a new firing attempt.

If firing is still not achieved, it may be that gas is not reaching the combustion head within the safety time period.

In this case increase gas firing delivery.

The arrival of gas at the sleeve is indicated by the U-type manometer (Fig. 26).

Once the burner has fired, proceed with calibration.

### 5.4 Burner calibration (gas operation)

The optimum calibration of the burner requires an analysis of the flue gases at the boiler outlet.

Adjust successively:

- 1 - High fire burner output
- 2 - Low fire burner output
- 3 - Air pressure switch
- 4 - Minimum gas pressure switch

#### Gas calibration

Adjust gas delivery to the amount of air at this position.

If delivery needs to be reduced, diminish outlet gas pressure and, if it is already very low, slightly close high fire adjustment valve. (if installed)

If delivery needs to be increased, increase outlet gas pressure.

#### 5.4.1 High fire output

High fire output of the burner must be set within the firing rate range shown on page 9.

#### 5.4.2 Low fire output

Burner power at low fire operation must be selected within the firing rate range shown on page 9.

Press switch 2) (Fig. 26) "output decrease" and keep it pressed until the low fire position is reached: the servomotor will close the air damper at the previously set value for oil and will control the opening of the low fire gas valve.

#### Adjusting gas delivery

Adjust gas delivery to the amount of air by adjusting the low fire gas valve VR1.

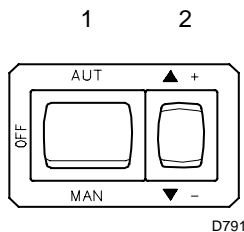

**Fig. 26**

Press switch 2) (Fig. 26) "output increase": the servomotor will open the air damper at the previously set value for oil and will control the opening of the high fire gas valve.

### 5.4.3 Air pressure switch - CO check

Adjust the air pressure switch after having performed all other burner adjustments with the air pressure switch set to the start of the scale (Fig. 27).

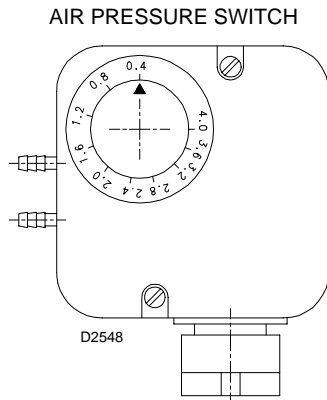

Fig. 27

With the burner operating in low fire, increase adjustment pressure by slowly turning the relative dial clockwise until the burner locks out.

Then turn the dial anti-clockwise by about 20% of the set point and repeat burner starting to ensure it is correct.

If the burner locks out again, turn the dial anti-clockwise a little bit more.



As a rule, the air pressure switch must block the formation of CO.

To check this, insert a combustion analyser into the chimney, slowly close the fan suction inlet (for example with cardboard) and check that the burner locks out, before the CO in the fumes exceeds 400 ppm.

The air pressure switch may operate in "differential" operation in two pipe system. If a negative pressure in the combustion chamber during pre-purging prevents the air pressure switch from switching, switching may be obtained by fitting a second pipe between the air pressure switch and the suction inlet of the fan. In this way the air pressure switch operates as a differential pressure switch.

### 5.4.4 Low gas pressure switch

Adjust the low gas pressure switch after having performed all the other burner adjustments with the pressure switch set at the start of the scale (Fig. 28).

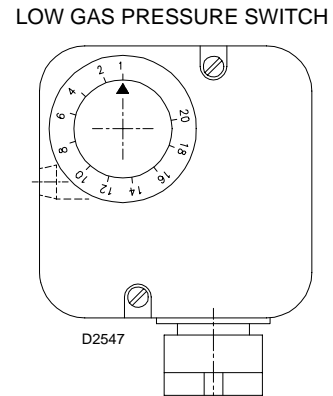

Fig. 28

With the burner operating at high fire, increase adjustment pressure by slowly turning the relative dial clockwise until the burner locks out.

Then turn the dial anti-clockwise by 0.8" WC and repeat burner starting to ensure it is uniform.

If the burner locks out again, turn the dial anti-clockwise again by 0.4" WC.

**6 Maintenance**

**6.1 Notes on safety for the maintenance**

The periodic maintenance is essential for the good operation, safety, yield and duration of the burner.

It allows you to reduce consumption and polluting emissions and to keep the product in a reliable state over time.



The maintenance interventions and the calibration of the burner must only be carried out by qualified, authorised personnel, in accordance with the contents of this manual and in compliance with the standards and regulations of current laws.

Before carrying out any maintenance, cleaning or checking operations:



disconnect the electricity supply from the burner by means of the main switch of the system



close the fuel interception tap

**Combustion**

The optimum calibration of the burner requires an analysis of the flue gases. Significant differences with respect to the previous measurements indicate the points where more care should be exercised during maintenance.

**Gas leaks**

Make sure that there are no gas leaks on the pipework between the gas meter and the burner.

**Flame inspection window**

Clean the flame inspection window (Fig. 29).

FLAME INSPECTION WINDOW

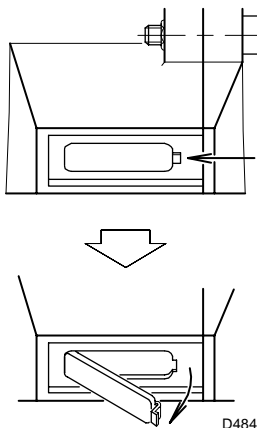

**Fig. 29**

**Combustion head**

Open the burner and make sure that all components of the combustion head are in good condition, not deformed by the high temperatures, free of impurities from the surroundings and correctly positioned. If in doubt, disassemble the elbow fitting 7) (Fig. 31, page 23).

**Nozzles (fuel oil)**

Do not clean the nozzle orifices.

The nozzle filters however may be cleaned or replaced as required. Replace the nozzles every 2-3 years or whenever necessary.

Combustion must be checked after the nozzles have been changed.

**UV scanner**

Clean the glass cover from any dust that may have accumulated. The UV scanner 1) (Fig. 30) is held in position by a pressure fit and can therefore be removed by pulling it outward .

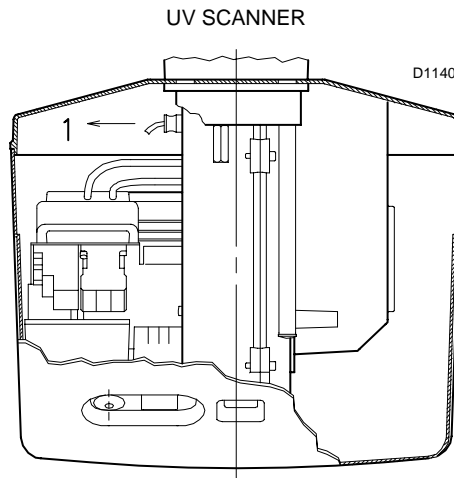

**Fig. 30**

**Flexible hoses (fuel oil)**

Check to make sure that the flexible hoses are still in good condition and that they are not crushed or otherwise deformed.

**Burner**

Check for excess wear or loose screws. Also make sure that the screws securing the electrical leads in the burner connections are fully tightened.

Clean the outside of the burner.

**Combustion**

Adjust the burner if the combustion values found at the beginning of the operation do not comply with the regulations in force, or do not correspond to good combustion. Record the new combustion values; they will be useful for subsequent comparison.

## 6.2 Opening the burner

### 6.2.1 To open the burner:

- switch off the electrical power.
  - Remove screws 1) and withdraw cover 2).
  - Disconnect the light-oil pipes 7).
  - Remove screw 5), the split pin 9) and pull the burner back by about 4" on the slide bars 6). Disconnect the electrode leads and then pull the burner fully back.
  - Tilt the burner as shown in the figure and fit the split pin 9) into one of the slide bar holes so that the burner remains in position
- Now extract the internal part 7) after having removed the screw 8).

### 6.2.2 To close the burner:

remove the split pin 9) and push the burner until it is about 4" from the sleeve. Re-connect the leads and slide the burner in until it comes to a stop. Refit screw 5), the split pin 9) and pull the leads gently out until they are slightly stretched. Reconnect the light-oil pipes.

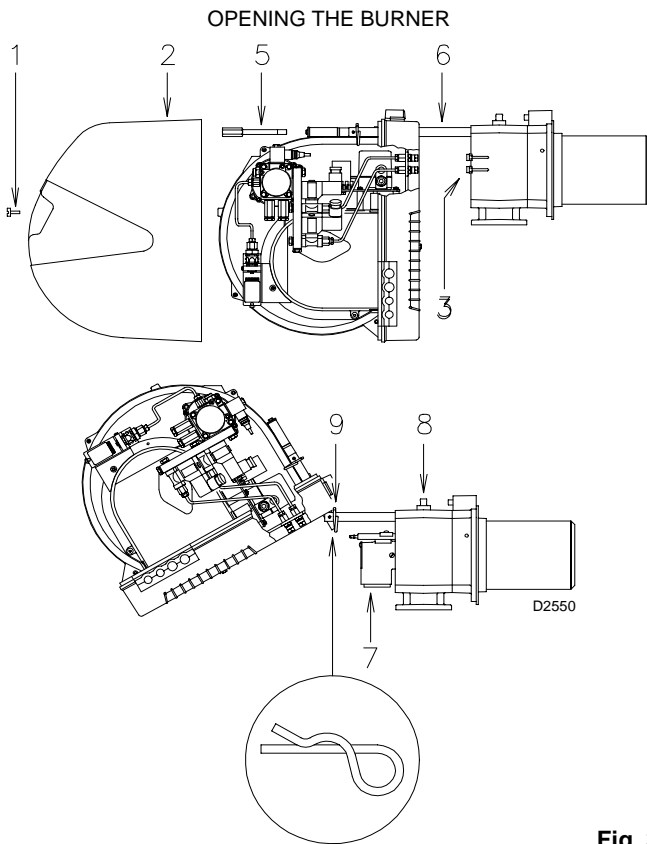

Fig. 31

## 6.3 Hydraulic system layout

- 1 Pump suction
- 2 Filter
- 3 Pump
- 4 Pressure regulator
- 5 Return pipe
- 6 By-pass screw
- 7 Pump return
- 8 Safety solenoid
- 9 Low fire valve
- 10 High fire valve
- 11 Filter
- M Pressure gauge
- P Low oil pressure switch
- V Vacuum gauge

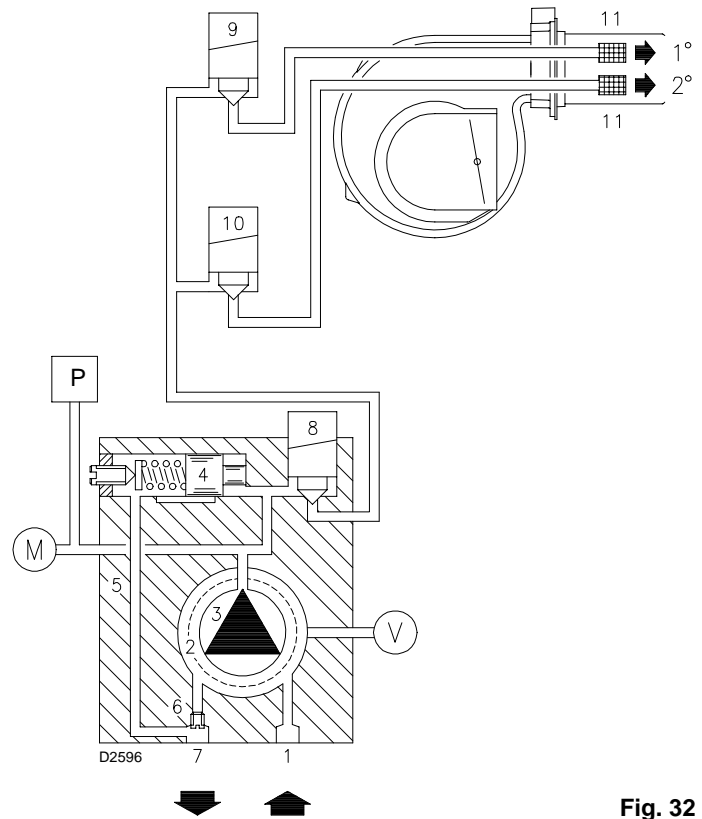

Fig. 32

### 6.3.1 Oil pressure switch

The oil pressure switch 26) (Fig. 1, page 7) is factory set to 145 PSI (10 bar). If the oil pressure goes below this value, the pressure switch stops the burner.

### 6.3.2 Combustion checks

#### CO<sub>2</sub>

It is better to set the burner with CO<sub>2</sub> not higher than 10% (with natural gas). In this way avoiding a loss of calibration setting (for example draft variation) that could cause combustion with little air and the production of CO.

#### CO

It must be not higher than 400 PPM.

**7 Electrical system****7.1 Electrical wiring****Notes on safety for the electrical wiring**

- The electrical wiring must be carried out with the electrical supply disconnected.
- Electrical wiring must be carried out by qualified personnel and in compliance with the regulations currently in force in the country of destination.  
Refer to the electrical layouts.
- The manufacturer declines all responsibility for modifications or connections different from those shown in the electrical layouts.
- Check that the electrical supply of the burner corresponds to that shown on the identification label and in this manual.
- Do not invert the neutral with the phase in the electrical supply line.  
Any inversion would cause a lockout due to firing failure.
- The electrical safety of the device is obtained only when it is correctly connected to an efficient earthing system, made according to current standards.  
It is necessary to check this fundamental safety requirement. In the event of doubt, have the electrical system checked by qualified personnel.  
Do not use the gas tubes as an earthing system for electrical devices.
- The electrical system must be suitable for the maximum input power of the device, as indicated on the label and in the manual, checking in particular that the section of the cables is suitable for the input power of the device.
- For the main power supply of the device from the electricity mains:
  - do not use adapters, multiple sockets or extensions;
  - use an omnipolar switch with an opening of at least  $\frac{1}{8}$ " (overvoltage category) between the contacts, as indicated by the current safety standards.
- Do not touch the device with wet or damp body parts and/or in bare feet.
- Do not pull the electric cables.

## 7.2 Field wiring connections

- For electrical connection use flexible cables according to local Regulations.
- The setting of the thermal overload must be according to the total burner amperage draw.
- The RLS 38-50 three-phase burners leave the factory preset for:
  - **208-230V** power supply: only in this case, if 460V power supply is required, change the fan motor connection from delta to double star and change the setting of the thermal overload as well;
  - or **575V** power supply;
- depending on the burner model (see page 6).
- The RLS 50 single-phase burner leaves the factory preset for **120V** power supply: if 230V power supply is required, change the fan motor connection as shown in (Fig. 33).

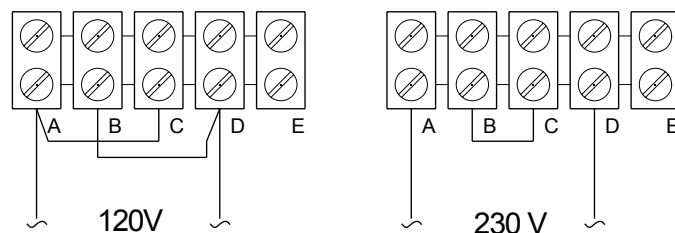

D8348

**Fig. 33**

The RLS 28-38-50 burners have been type-approved for intermittent operation. This means they should compulsorily be stopped at least once every 24 hours to enable the control box to check its own efficiency at start-up. Burner halts are normally provided for automatically by the boiler load control system.

If this is not the case, a time switch should be fitted in series to **OC** to provide for burner shut-down at least once every 24 hours.

## 7.3 External fuses (see the electrical diagram)

### RLS 28 - 38 - 50 Single-phase burners

	RLS 28	RLS 38	RLS 50	
	120V	120V	120V	230V
FU1 (A)	T10	T10	T15	T10
FU2 (A)	T6			

### RLS 38 - 50 Three-phase burners

	208/230V	460V	575V
FU1 (A)	T6	T6	T4
FU2 (A)	T6	T6	T6



**WARNING**

When installing for the first time and after any maintenance work, make sure the gas valves are connected properly to the orange terminals before proceeding to ignite the burner. Insert auxiliary lamps or check, with the aid of a tester, that power is not being supplied to the valves during standby or pre-purging. Burner ignition with the gas valves open during pre-purging may cause the generator to burst.

- **Do not invert the neutral with the phase wire in the electricity supply line.**
- **Only use original spare parts to replace the components.**

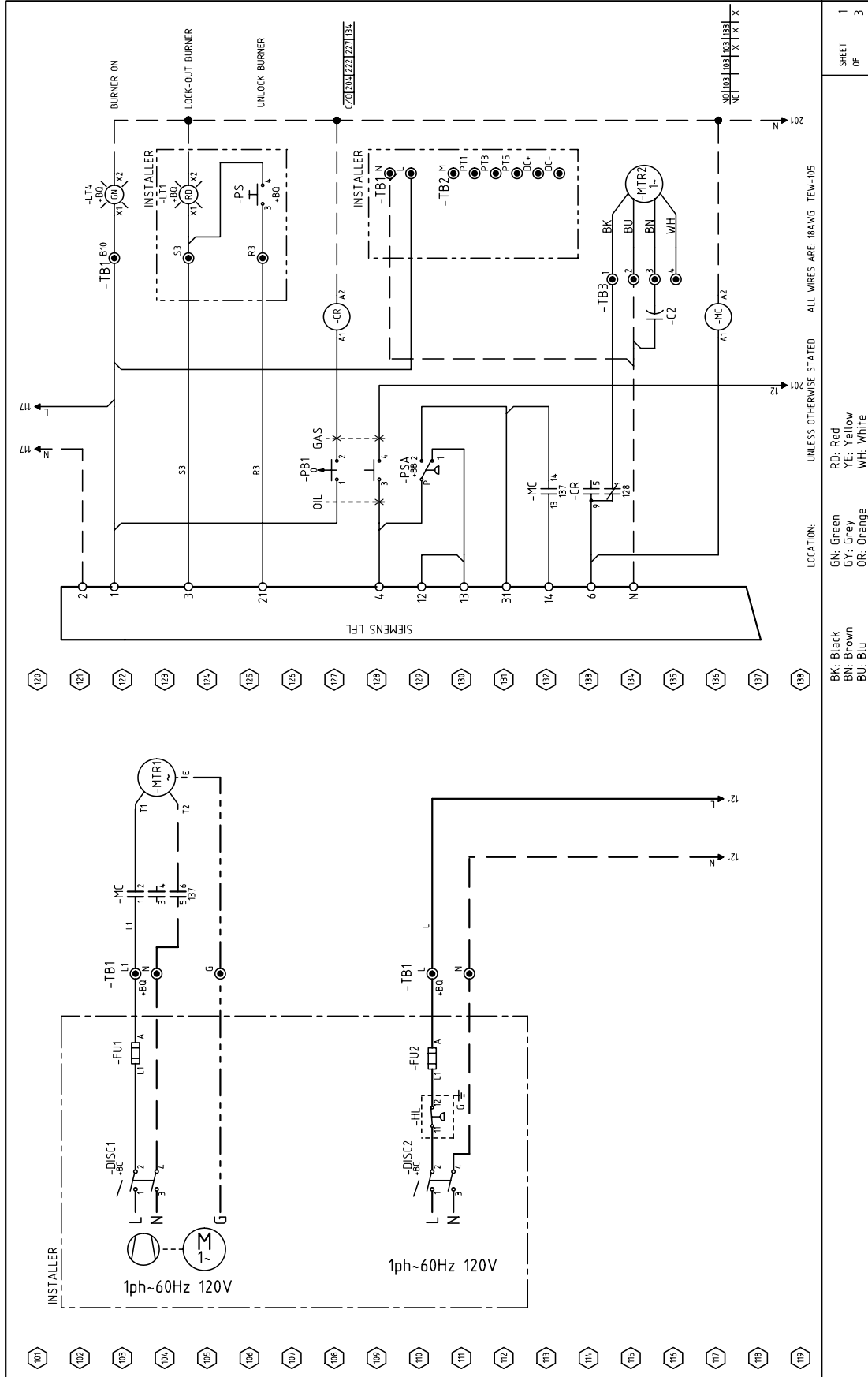

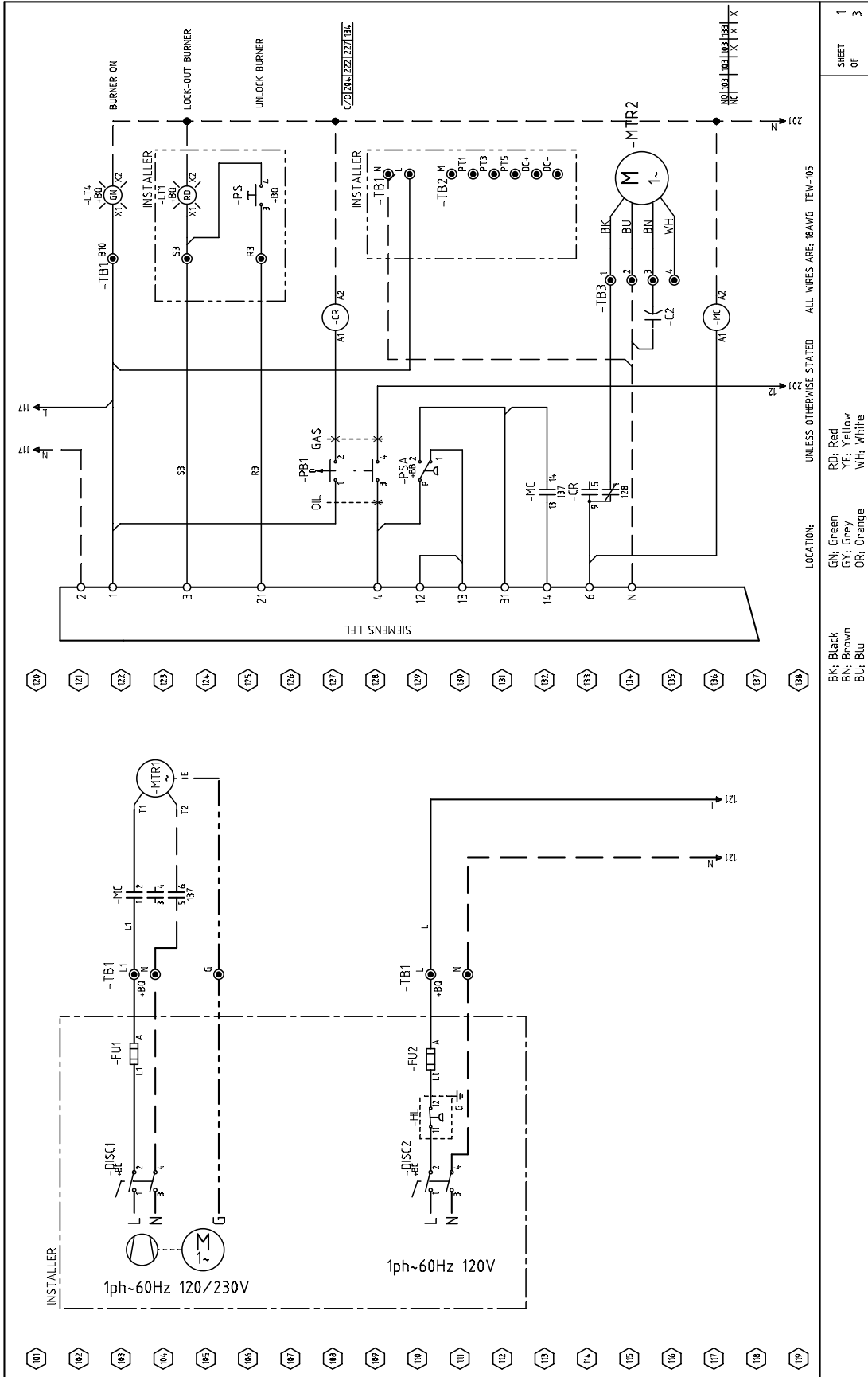

101	102	103	104	105	106	107	108	109	110	111	112	113	114	115	116	117	118	119	
120	121	122	123	124	125	126	127	128	129	130	131	132	133	134	135	136	137	138	139



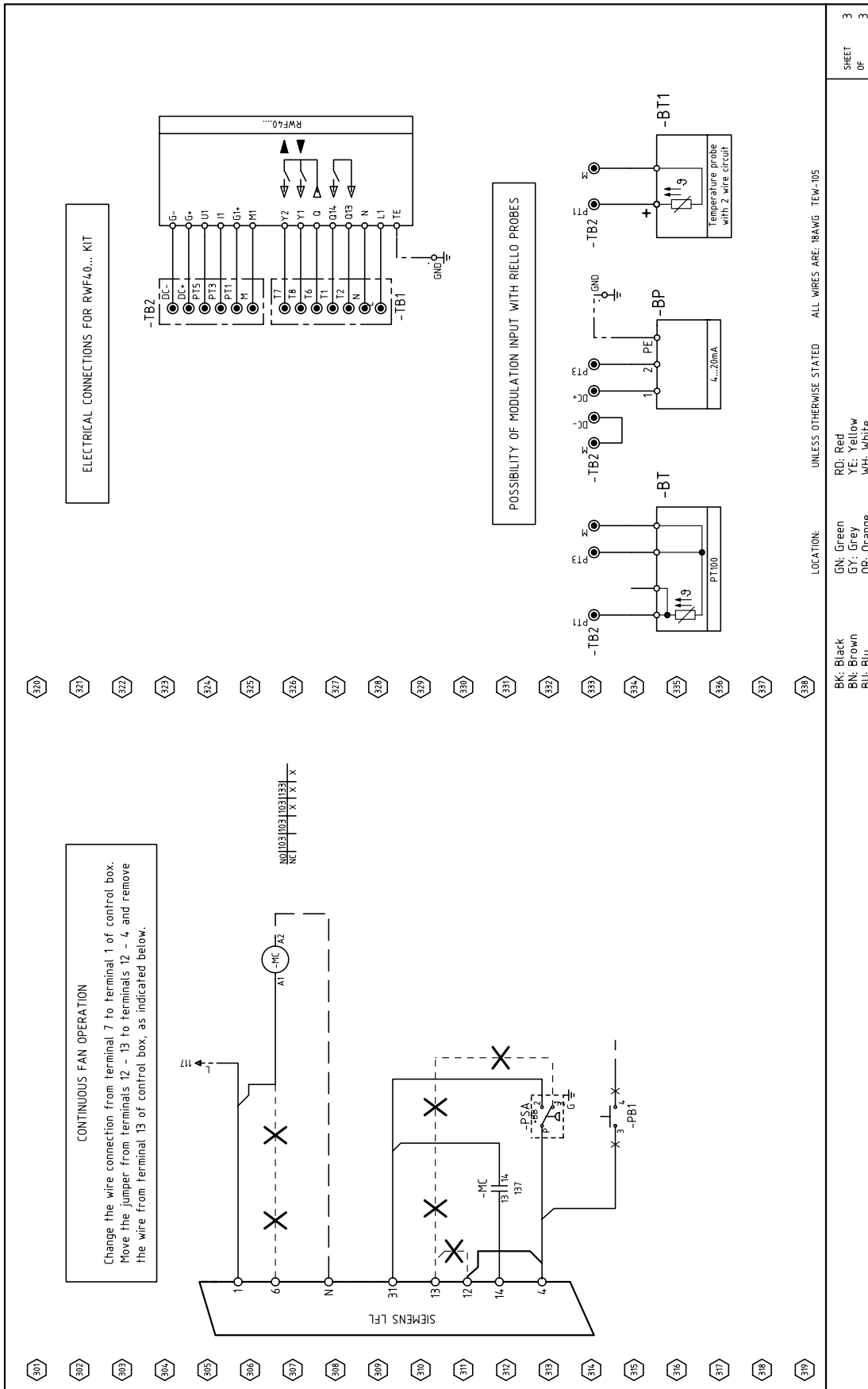

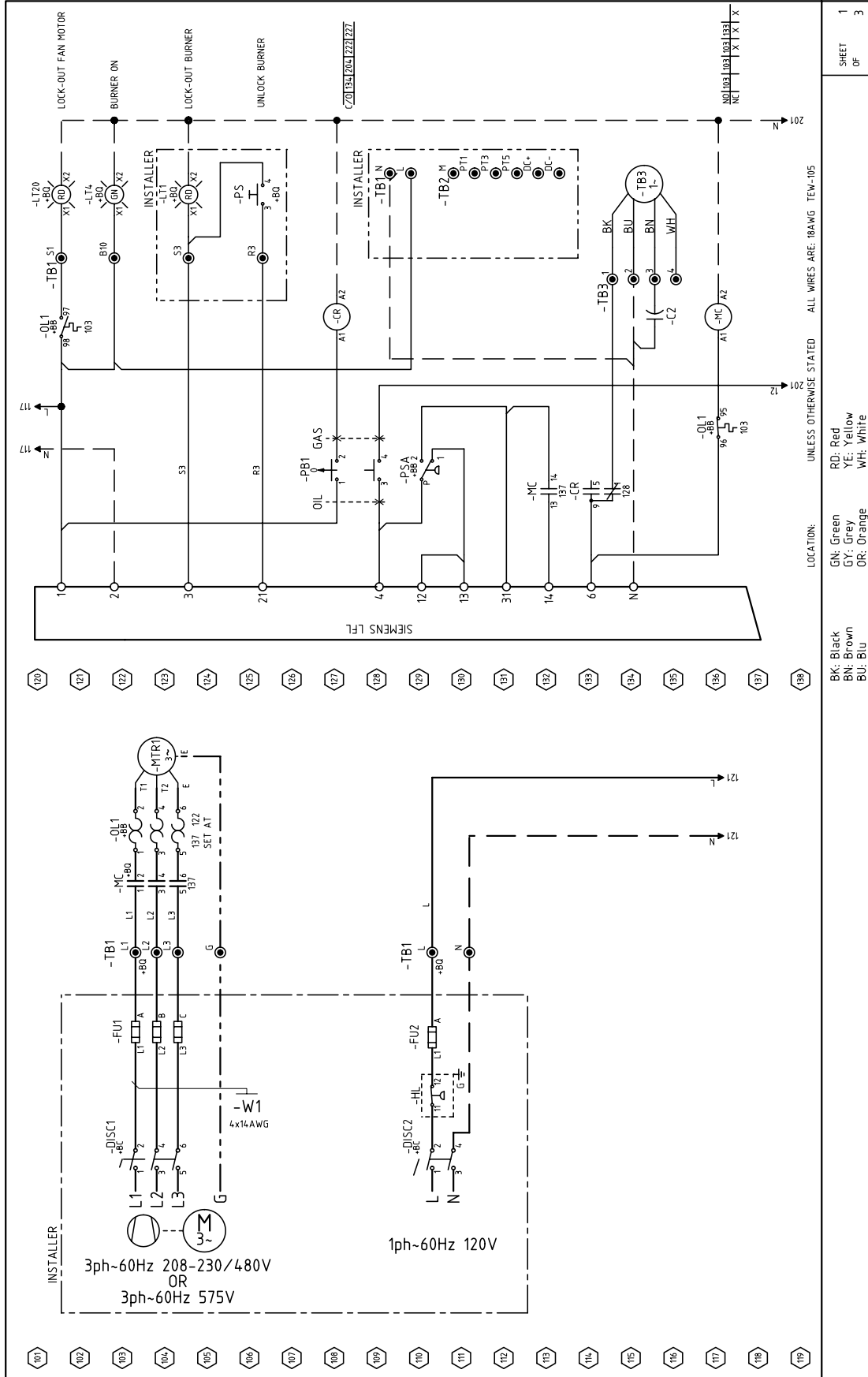

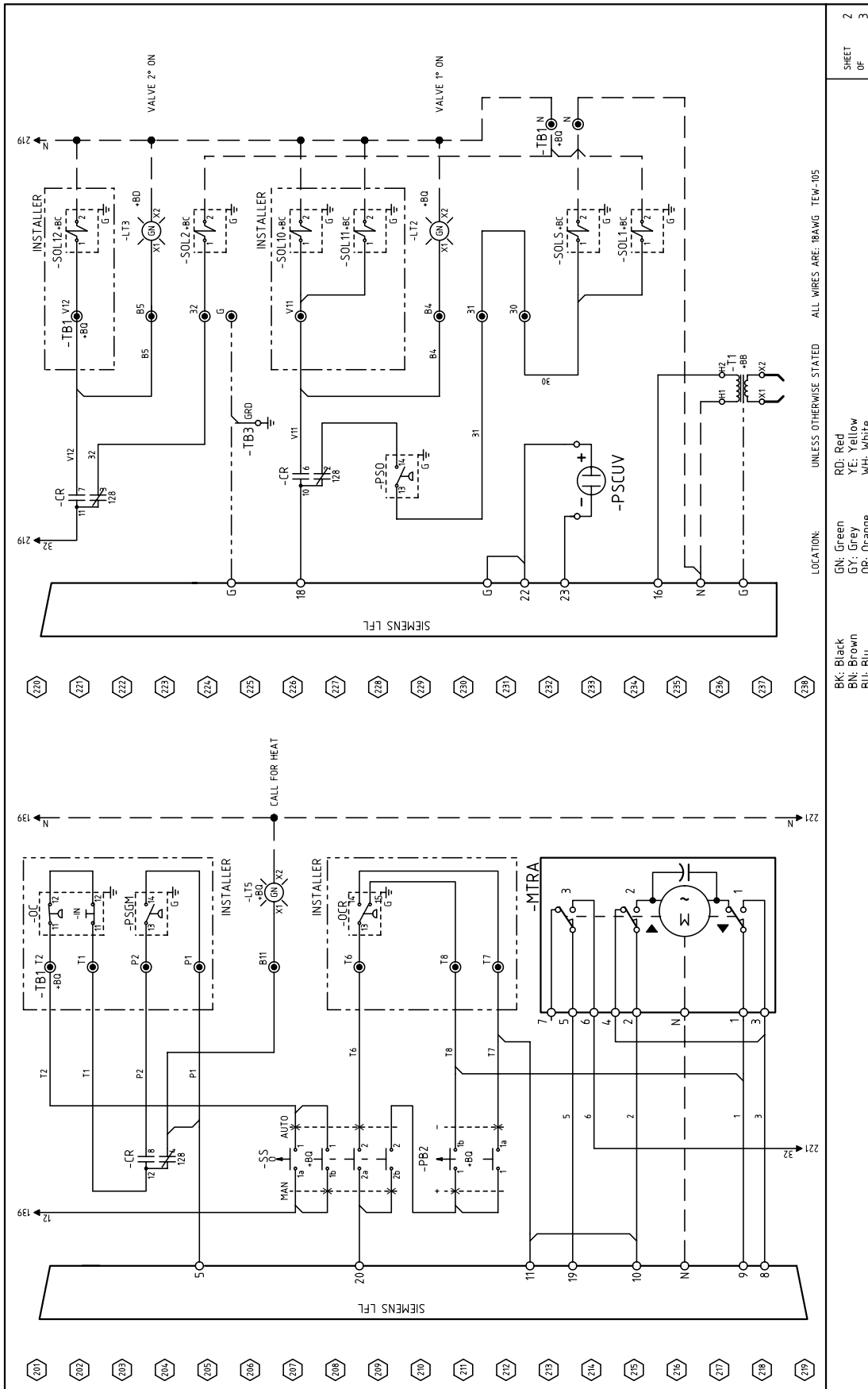

SHEET 2  
OF 3



## Key to Layouts

- BP - Pressure probe
- BT - Tree-wire probe Pt100
- BT1 - Temperature probe with two-wire circuit
- + BB - Components on board burners
- + BQ - Components on board main panel
- + BC - Components on board boiler
- CR - Relay
- C2 - Pump motor capacitor
- DISC1 - Disconnect switch motor
- DISC2 - Disconnect switch auxiliary
- FU1 - Motor fuse
- FU2 - Auxiliary fuse
- HL - High limit control
- LFL - Control box
- LT1 - Remote lock-out signal
- LT2 - Low fire signal (gas)
- LT3 - High signal (gas)
- LT4 - Power on signal
- LT5 - Permission ok
- LT20 - Lock-out-fan motor
- MC - Motor contactor
- MTRA - Servomotor
- MTR1 - Fan motor
- MTR2 - Pump motor
- OC - Operating control
- OCR - High-low control  
If the burner is to be set up for single stage operation  
install jumper between terminals T6 and T8.
- OL1 - Thermal overload
- PB1 - OIL/GAS selector
- PB2 - Button for:  
= power reduction  
= power increaser
- PS - Remote lock-out reset
- PSA - Air pressure switch
- PSCUV - UV scanner
- PSGM - Low gas pressure switch
- PSO - Oil pressure switch
- SOL1 - Low fire solenoid valve
- SOL2 - High fire solenoid valve
- SOL10 - Safety gas valve
- SOL11 - Low fire gas valve
- SOL12 - High fire gas valve
- SOLS - Safety solenoid valve
- SS - Switch for following operations :  
MAN= manual  
AUT= automatic  
OFF
- T1 - Ignition transformer
- TB1 - Burner terminal strip
- TB2 - Auxiliary terminal strip
- TB3 - Burner group
- W1 - Cable fan motor

## 7.4 Burner firing rates according to air density

above sea level		average barom. pressure		CORRECTION FACTOR F Air temperature °F (°C)							
ft	m	" W.C.	mbar	0 (0°C)	41 (5°C)	50 (10°C)	59 (15°C)	68 (20°C)	77 (25°C)	86 (30°C)	104 (40°C)
0	0	399	1013	1,087	1,068	1,049	1,031	1,013	0,996	0,980	0,948
329	100	394	1000	1,073	1,054	1,035	1,017	1,000	0,983	0,967	0,936
658	200	389	989	1,061	1,042	1,024	1,006	0,989	0,972	0,956	0,926
987	300	385	978	1,050	1,031	1,013	0,995	0,978	0,962	0,946	0,916
1316	400	380	966	1,037	1,018	1,000	0,983	0,966	0,950	0,934	0,904
1645	500	376	955	1,025	1,007	0,989	0,972	0,955	0,939	0,923	0,894
1974	600	372	944	1,013	0,995	0,977	0,960	0,944	0,928	0,913	0,884
2303	700	367	932	1,000	0,982	0,965	0,948	0,932	0,916	0,901	0,872
2632	800	363	921	0,988	0,971	0,954	0,937	0,921	0,906	0,891	0,862
2961	900	358	910	0,977	0,959	0,942	0,926	0,910	0,895	0,880	0,852
3290	1000	354	898	0,964	0,946	0,930	0,914	0,898	0,883	0,868	0,841
3947	1200	346	878	0,942	0,925	0,909	0,893	0,878	0,863	0,849	0,822
4605	1400	337	856	0,919	0,902	0,886	0,871	0,856	0,842	0,828	0,801
5263	1600	329	836	0,897	0,881	0,866	0,851	0,836	0,822	0,808	0,783
5921	1800	321	815	0,875	0,859	0,844	0,829	0,815	0,801	0,788	0,763
6579	2000	313	794	0,852	0,837	0,822	0,808	0,794	0,781	0,768	0,743

**Tab. K**

- Plot a vertical line from Point A as shown in (Fig. 34) and find the maximum pressure H2 of the firing rate.
- Multiply H2 by F to obtain the maximum reduced pressure H3 of the firing rate.

$$H3 = H2 \times F \quad (\text{" W.C.})$$

If H3 is greater than H1, as shown in (Fig. 34), the burner delivers the output required.

If H3 is lower than H1, the burner's delivery must be reduced. A reduction in delivery is accompanied by a reduction of the pressure in the combustion chamber:

- Qr = reduced delivery
- H1r = reduced pressure

$$H1r = H1 \times \left(\frac{Qr}{Q}\right)^2$$

**Example**, a 5% delivery reduction:

- Qr = Q x 0.95
- H1r = H1 x (0.95)<sup>2</sup>

Steps 2 - 5 must now be repeated using the new Qr and H1r values.

**NOTE:**

**the combustion head must be adjusted in respect to the equivalent delivery Qe.**

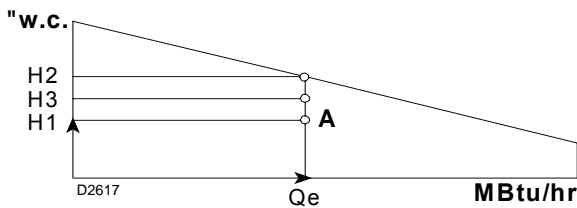

**Fig. 34**

The FIRING RATE area values have been obtained considering a surrounding temperature of 68°F (20°C), and an atmospheric pressure of 398" W.C. and with the combustion head adjusted as shown on page 14.

The burner may be required to operate with combustion air at a higher temperature and/or at higher altitudes.

Heating of air and increase in altitude produce the same effect: the expansion of the air volume, i.e. the reduction of air density.

The burner fan's delivery remains substantially the same, but the oxygen content per cubic meter and the fan's head are reduced.

It is therefore important to know if the maximum output required of the burner at a given combustion chamber pressure remains within the burner's firing rate range even at different temperature and altitude conditions. Proceed as follows to check the above:

- Find the correction factor F in the Tab. K for the plant's air temperature and altitude.
- Divide the burner's delivery Q by F in order to obtain the equivalent delivery Qe:

$$Qe = Q : F \quad (\text{MBTU/h})$$

- In the firing rate range of the burner, (Fig. 34), indicate the work point defined by:

- Qe = equivalent delivery
- H1 = combustion chamber pressure

The resulting point A must remain within the firing rate range.

### 7.5 Flame signal

Min value for a good signal: 70  $\mu$ A.

If the value is lower, it can be due to:

- Worn scanner;
- Low current;
- Bad set up of the burner.

In order to measure the current, use a microammeter of 100 mA c.c., connected to the scanner, with a capacitor of 100 mF - 1V c.c. at the same level of the instrument. See (Fig. 35).

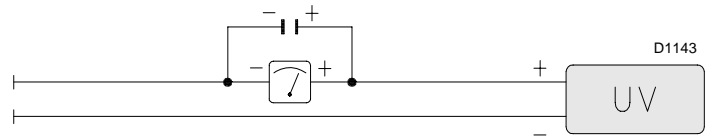

Fig. 35

### 7.6 Sequence of operation

LFL 1.335 Series 01

t1	30	t6	optional
t2	2	t7	12
t3	4	t8	4
t4	20		
t5	optional		

Tab. L

#### Legend for the times

- t1 Pre-purge time with air damper open
- t2 Safety time
- t3 Pre-ignition time, short (ignition transformer on terminal 16)
- t4 Interval between start of t2 and release of valve at terminal 19
- t5 Interval between end of t4 and release of load controller or valve at terminal 20
- t5 Running time of air damper into OPEN position
- t6 Running time of air damper into low-flame position (MIN)
- t7 Permissible after-burn time
- t8 Interval until OPEN command for the air damper is given

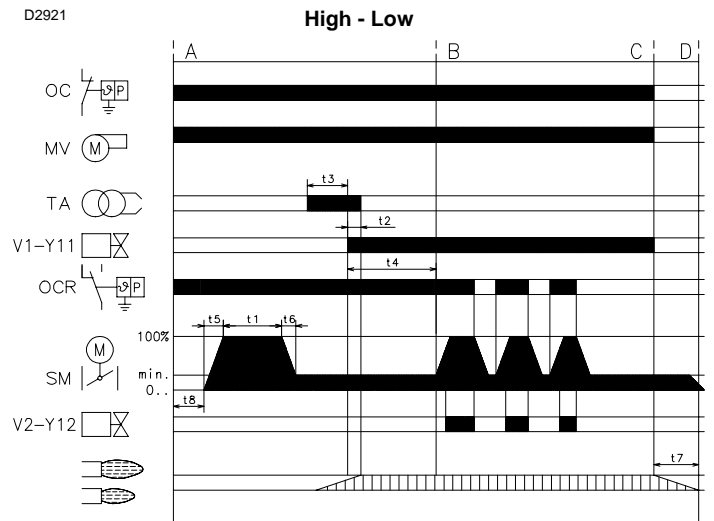

Fig. 36

### 7.7 Firing failure

If the burner does not fire, it locks out within 2.5 seconds from opening the pilot valve and then within 5 seconds from opening the main valves.

### 7.8 Burner flame goes out during operation

If the flame should accidentally go out during operation, the burner will lock out within 1s.

**Control program under fault conditions and lock-out indication** In case of any disturbance, the sequence mechanism stops and with it the lock-out indicator. The symbol above the reading mark of the indicator gives the type of disturbance:

- ◀ **No start**, e.g. because one contact is not closed. Lock-out during or after control program sequence due to extraneous light (e.g. non-extinguished flames, leaking fuel valves, defects in the flame supervision circuit, etc.).
- ▲ **Interruption of startup sequence**, because the OPEN signal has not been delivered to terminal 8 by cam 1 (gas) or cam 4 (oil). Terminals 6, 7 and 14 remain under voltage until the fault has been corrected!
- P **Lockout**, because there is no air pressure indication at the beginning of air pressure control.  
**Every air pressure failure after this moment in time leads to lock-out, too!**
- **Lock-out** due to a fault in the flame supervision circuit.
- ▼ **Interruption of startup sequence**, because the position signal for the low-flame position has not been delivered to terminal 8 by cam 3 (gas) or cam 5 (oil). Terminals 6, 7 and 14 remain under voltage until the fault has been corrected!
- 1 **Lock-out**, because no flame signal is present after completion of the (1st) safety time.
- 2 **Lock-out**, because no flame signal has been received on completion of the 2nd safety time (flame signal of the main flame with interrupted pilot burners).
- | **Lock-out**, because the flame signal has been lost during burner operation.

If lock-out occurs at any other moment in time between the start and the pre-ignition which is not marked by a symbol, this is usually caused by a premature, i.e. faulty flame signal, e.g. caused by a self-igniting UV tube.

**BURNER START UP REPORT**

Model number: _____	Serial number: _____
Project name: _____	Start-up date: _____
Installing contractor: _____	Phone number: _____

<b>GAS OPERATION</b>			
Gas Supply Pressure: _____	CO <sub>2</sub> : Low Fire _____	High Fire _____	
Main Power Supply: _____	O <sub>2</sub> : Low Fire _____	High Fire _____	
Control Power Supply: _____	CO: Low Fire _____	High Fire _____	
Burner Firing Rate: _____	NO <sub>x</sub> : Low Fire _____	High Fire _____	
Manifold Pressure: _____	Net Stack Temp - Low Fire: _____	High Fire _____	
Pilot Flame Signal: _____	Comb. Efficiency - Low Fire: _____	High Fire _____	
Low Fire Flame Signal: _____	Overfire Draft: _____		
High Fire Flame Signal: _____			

<b>OIL OPERATION</b>			
Oil supply pressure: _____	CO <sub>2</sub> : Low Fire _____	High Fire _____	
Oil suction pressure: _____	O <sub>2</sub> : Low Fire _____	High Fire _____	
Control Power Supply: _____	CO: Low Fire _____	High Fire _____	
Burner Firing Rate: _____	NO <sub>x</sub> : Low Fire _____	High Fire _____	
Low Fire Flame Signal: _____	Net Stack Temp - Low Fire: _____	High Fire _____	
High Fire Flame Signal: _____	Comb. Efficiency - Low Fire: _____	High Fire _____	
Low Fire Nozzle Size: _____	Overfire Draft: _____		
High Fire Nozzle Size: _____	Smoke number: _____		

<b>CONTROL SETTINGS</b>			
Operating Setpoint: _____	Low Oil Pressure: _____		
High Limit Setpoint: _____	High Oil Pressure: _____		
Low Gas Pressure: _____	Flame Safeguard Model Number: _____		
High Gas Pressure: _____	Modulating Signal Type: _____		

<b>NOTES</b> <hr/> <hr/> <hr/> <hr/> <hr/>
---

**8 Spare parts**

**8.1 Exploded spare parts list**

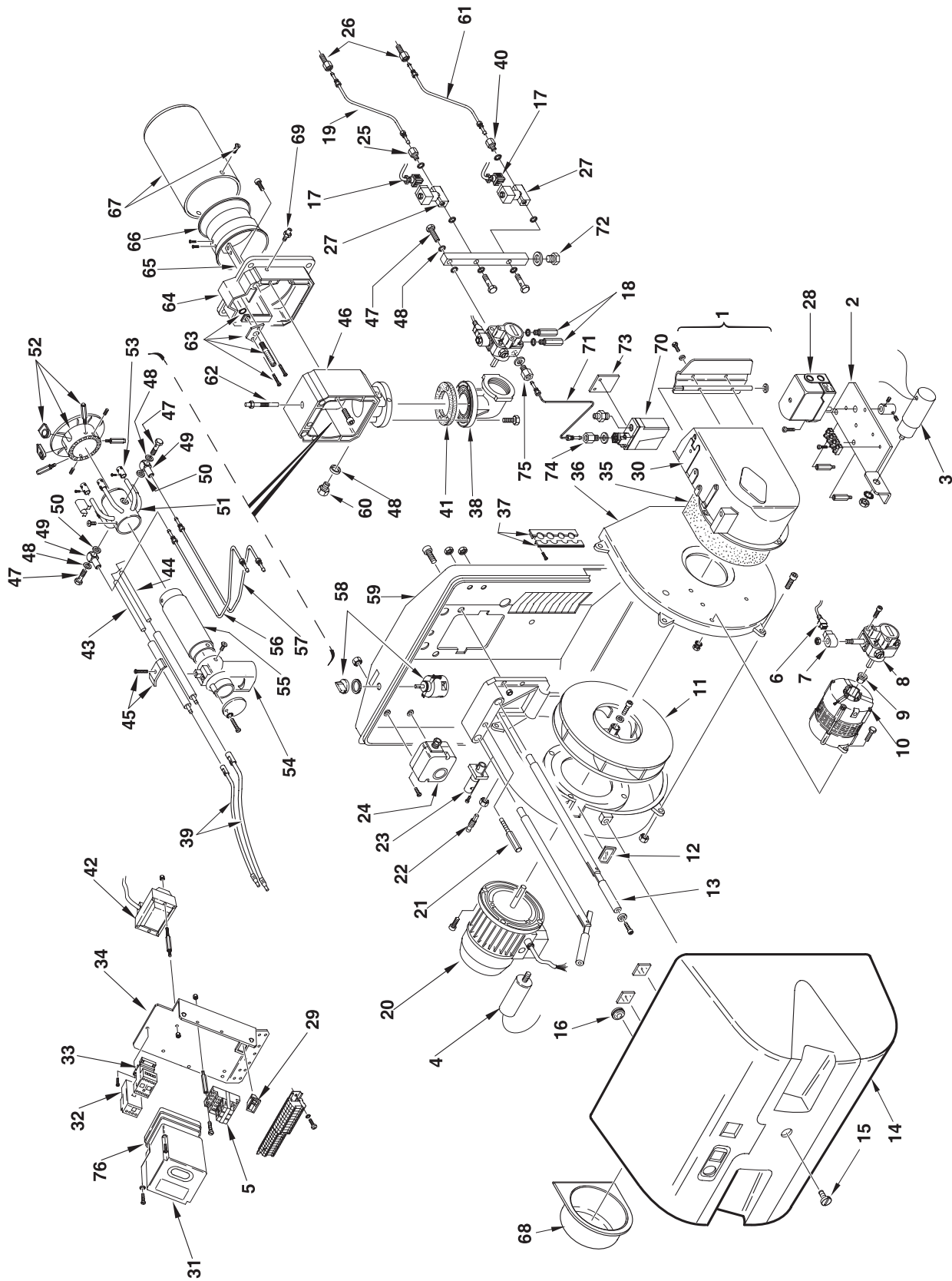

## 8.2 Spare parts list

N.	COD.	C9531000 (3483270)	C9532000 (3484170)	C9533000 (3484670)	C9533001 (3484670)	(3483270)	DESCRIPTION	*
1	3012508	•	•	•	•	•	AIR DAMPER ASSEMBLY	
2	3013013	•	•	•	•	•	ANCHOR PLATE	
3	3013014	•	•	•	•	•	CONDENSER	
4	3012988	•					CONDENSER	
5	3012992	•	•	•	•	•	OVERLOAD	
6	3013015	•	•	•	•	•	JACK	
7	3013016	•	•	•	•	•	COIL	
8	3013017	•	•	•	•	•	PUMP	
9	3006717	•	•	•	•	•	JOINT	
10	3013018	•	•	•	•	•	MOTOR	
11	3012985	•					FAN	
11	3012986		•				FAN	
11	3003760			•	•	•	FAN	
12	3003763	•	•	•	•	•	INSPECTION WINDOW	
13	3003842	•	•	•	•	•	BAR	
14	3012987	•	•	•	•	•	COVER	
14	3013873					•	COVER	
15	3003766	•	•	•	•	•	SCREW	
16	3007627	•	•	•	•	•	MEMBRAN	
17	3012953	•	•	•	•	•	SOCKET	
18	3013037	•	•	•	•	•	CONNECTOR	
19	3013025	•	•	•	•	•	TUBE	
20	3012993	•	•				MOTOR	
20	3012994			•	•		MOTOR 208-230/460 V	
20	3013057			•	•		MOTOR 575 V	
20	3013869			•			MOTOR 575 V	
21	3003778	•	•	•	•	•	SHORT SHAFT	
22	3003891	•	•	•	•	•	CONNECTOR	
23	C5360028	3003396	•	•	•	•	U.V. DETECTOR	
24	3012948	•	•	•	•	•	AIR PRESSURE SWITCH	
25	3003376	•	•	•	•	•	CONNECTOR	
26	3012319	•	•	•	•	•	CONNECTOR	
27	3012952	•	•	•	•	•	NEEDLE VALVE	
28	3013008	•	•	•	•	•	SERVOMOTOR	
29	3003770	•	•	•	•	•	SWITCH	
30	3012509	•	•	•	•	•	AIR INTAKE	
31	C5830008	3012955	•	•	•	•	CONTROL BOX LFL 1.335	
32	3012991			•			OVERLOAD 208-230/460 V	
32	3013023				•		OVERLOAD 575 V	

N.	COD.					DESCRIPTION	*
		C9531000 (3483270)	C9532000 (3484170)	C9533000 (3484670)	C9533001 (3484670) (3483270)		
33	3012989	•	•			CONTACTOR	
33	3012990			•	•	CONTACTOR	
33	20006633					• CONTACTOR	
34	3013019	•	•	•	•	SUPPORT	
34	3013878					• SUPPORT	
35	3003830	•	•	•	•	SOUND DAMPING	
36	3012316	•	•	•	•	HALF-SHELL	
37	3003780	•	•	•	•	FAIRLEAD	
38	3013004	•	•	•	•	FLANGE AND ELBOW	
39	3012995	•	•	•	•	H.T.LEAD	
40	3006719	•	•	•	•	CONNECTOR	
41	3005483	•	•	•	•	SEAL	
42	3012938	•	•	•	•	TRANSFORMER	
43	3013020	•	•	•	•	ELECTROD	
44	3013021	•	•	•	•	ELECTROD	
45	3003409	•	•	•	•	U BOLT	
46	3013130	•	•	•	•	MANIFOLD	
47	3006721	•	•	•	•	SCREW	
48	3007077	•	•	•	•	SEAL	
49	3006722	•	•	•	•	CONNECTOR	
50	3003381	•	•	•	•	SEAL	
51	3013074	•	•			GAS HEAD	
51	3013075			•	•	GAS HEAD	
52	3013022	•	•	•	•	DIFFUSER DISC	
53	3012303	•	•			GAS NOZZLE	
54	3003854	•	•	•	•	ELBOW	
55	3012304	•	•	•	•	TUBE	
56	3012306	•	•	•	•	TUBE	
57	3012308	•	•	•	•	TUBE	
58	3012310	•	•	•	•	COMMUTATOR	
59	3012323	•	•	•	•	FRONT SHIELD	
59	3013879					• FRONT SHIELD	
60	3003681	•	•	•	•	CONNECTOR	
61	3013024	•	•	•	•	TUBE	
62	3003873	•	•	•	•	TEST POINT	
63	3003797	•	•	•	•	CONTROL DEVICE	
64	3003798	•	•			FRONT PIECE	
64	3003838			•	•	FRONT PIECE	
65	3003799	•	•			SQUARE	
65	3003803			•	•	SQUARE	

N.	COD.					DESCRIPTION	*
		C9531000 (3483270)	C9532000 (3484170)	C9533000 (3484670)	C9533001 (3484670) (3483270)		
66	3003805	•				SHUTTER	
66	3012312	•				SHUTTER	
66	3003806			•	•	SHUTTER	
67	3012313	•				END CONE	
67	3012314	•				END CONE	
67	3003811			•	•	END CONE	
68	3013874				•	PROTECTION	
69	3003322	•	•	•	•	CONNECTOR	
70	3012384	•	•	•	•	OIL PRESSURE SWITCH	
71	3013076	•	•	•	•	TUBE	
72	3003681	•	•	•	•	NUT	
73	3013077	•	•	•	•	SUPPORT	
74	3006724	•	•	•	•	CONNECTOR	
75	3006719	•	•	•	•	CONNECTOR	
76	C5360002 3013010	•	•	•	•	CONTROL BOX BASE	

## \*

## ADVISED PARTS

- A = Spare parts for minimum fittings  
A+B = Spare parts for basic safety fittings  
A+B+C = Spare parts for extended safety fittings



RIELLO S.p.A.  
I - 37045 Legnago (VR)  
Tel.: +39.0442.630111  
[http:// www.rielloburners.com](http://www.rielloburners.com)



35 Pond Park Road  
Hingham, Massachusetts,  
U.S.A. 02043

RIELLO BURNERS NORTH AMERICA

**1-800-4-RIELLO**  
1-800-474-3556

2165 Meadowpine Blvd.  
Mississauga, Ontario,  
Canada L5N 6H6

<http://www.riello-burners.com>