

Gas Burners



RS 28/1 - 38/1

On - Off Operation

CONTENTS

TECHNICAL DATA	page 3
Burner models	3
Accessories	3
Burner description	4
Packaging - Weight	4
Max. dimensions	4
Standard equipment	4
Firing rates	5
Minimum furnace dimensions	5
Gas pressure	6
Gas piping	6
INSTALLATION	7
Boiler plate	7
Blast tube length	7
Securing the burner to the boiler	7
Ignition pilot adjustment	7
Combustion head adjustment	8
Gas piping	9
Adjustments before firing	10
Burner starting	10
Burner firing	10
Burner calibration:	11
1 - Firing output	11
2 - Maximum output	11
3 - Air pressure switch	12
4 - Low gas pressure switch	12
Flame present check	12
Maintenance	13
Propane operation	14
Appendix	15
Switchboard layout	16
Appendix - Burner firing rates according to air density	18
Start up report	22

N.B.

Figures mentioned in the text are identified as follows:

- 1)(A) = part 1 of figure A, same page as text;
- 1)(A)p.4 = part 1 of figure A, page number 4.

WARNING

If you smell gas:

- Do not touch any electrical items.
- Open all windows.
- Close all gas supply valves.
- Contact your local gas authority immediately.

Do not store flammable or hazardous materials in the vicinity of fuel burning appliances.

Improper installation, adjustment, alteration, service or maintenance can cause property damage, personal injury or death. Refer to this manual for instructional or additional information. Consult a certified installer, service representative or the gas supplier for further assistance.

Burner shall be installed in accordance with manufacturers requirements as outlined in this manual, local codes and authorities having jurisdiction.

TECHNICAL DATA

MODEL		RS 28/1	RS 38/1
Output ⁽¹⁾	MBtu/hr kW	617 - 1320 181 - 387	880 - 1761 258 - 516
Fuel		Natural gas/ propane gas	
- Max delivery	SCFH	1320	1761
- Pressure at maximum delivery ⁽²⁾	" W.C.	3.4	3.03
Operation		On/ Off	
Standard applications		Hot water, steam, thermal oil	
Ambient temperature	°F	32 - 104 (0 - 40 °C)	
Combustion air temperature	°F max	140 (60 °C)	
Main power supply (+/- 10%)	V/Ph/Hz	120/1/60	
Fan motor	rpm W - HP V A	3400 370 - 0.5 120 5.2	
Motor capacitor	µF	45	
Ignition transformer	V1 - V2 I1 - I2	120 V - 1 x 7 kV 1.6 A - 23 mA	
Electrical power consumption	W max	600	600
Electrical protection		NEMA 1	
Noise levels ⁽³⁾	dBA	70	72

(1) Reference conditions: Ambient temperature 68 °F (20°C) - Barometric pressure 394" WC - Altitude 329 ft a.s.l.

(2) Pressure at test point 8)(A)p.4, with zero pressure in the combustion chamber, with open gas ring 2)(B)p.8 at maximum burner output

(3) Sound pressure measured in manufacturer's combustion laboratory, with burner operating on test boiler and at maximum rated output.

Burner models designation:

Model	Code	Voltage	Flame safeguard
RS 28/1	C9521100 (3782070)	120/1/60	Burner mounted
RS 38/1	C9522100 (3782170)	120/1/60	Burner mounted

ACCESSORIES (optional):

Kit for lengthening the combustion head

L = Standard length

L1 = Length obtainable with the kit

COD. 3010262 L = 8 1/2" L1 = 13 13/16" • RS 28/1

COD. 3010263 L = 8 1/2" L1 = 13 13/16" • RS 38/1

Gas train according to ul standards: see page 9.

Important:
The installer is responsible for the supply and installation of any required safety device(s) not indicated in this manual.

BURNER DESCRIPTION (A)

- 1 Combustion head
- 2 Ignition electrode
- 3 Screw for combustion head adjustment
- 4 Sleeve
- 5 Low air pressure switch (differential operating type)
- 6 Flame sensor probe (flame rod)
- 7 Air pressure test point
- 8 Gas pressure test point and head fixing screw
- 9 Screw securing fan to sleeve
- 10 Slide bars for opening the burner and inspecting the combustion head
- 11 Indexed selector. Opens the fan air damper to the value needed by the burner delivery.
- 12 Plate with four hole knock-outs for electrical cable routing
- 13 Air inlet to fan
- 14 Gas input pipework
- 15 Gas train connection flange
- 16 Boiler mounting flange
- 17 Flame stability disk
- 18 Flame inspection window
- 19 Pilot burner attachment
- 20 Flame safeguard with lock-out pilot light and lock-out reset button
- 21 Terminal strip for electrical connections
- 22 Air damper
- 23 Plug-socket on ionisation probe (flame rod) cable
- 24 Ignition pilot

Note

If the flame safeguard 20(A) pushbutton lights up, it indicates that the burner is in lock-out. To reset, press the pushbutton.

PACKAGING - WEIGHT (B)

Approximate measurements.

- The burner are shipped in cardboard boxes with the maximum dimensions shown in Table (B).
- The weight of the burner complete with packaging is indicated in Table (B).

MAX. DIMENSIONS (C)

Approximate measurements.

The maximum dimensions of the burner are given in (C). Note that if you need to examine the combustion head, the burner must be pulled backward on the slide bars and turned upward.

The maximum dimension of the burner, without the cover, when open is given by measurement H.

STANDARD EQUIPMENT

- 1 - Gas train flange
- 1 - Flange gasket
- 4 - Flange fixing screws
- 1 - Burner head gasket
- 4 - Screws to secure the burner flange to the boiler: 3/8 W x 1"
- 1 - Instruction booklet
- 1 - Spare parts list

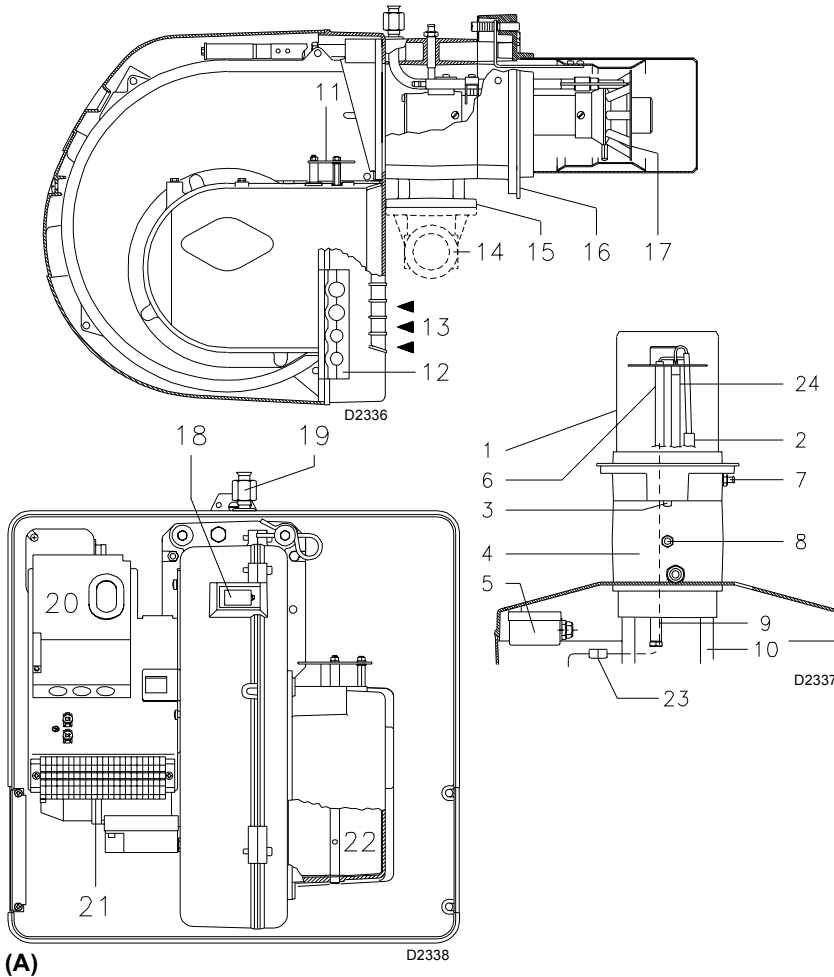

inch	A	B	C	lbs
RS 28/1	39 ³¹ / ₃₂ "	24 ¹³ / ₁₆ "	19 ¹¹ / ₁₆ "	82
RS 38/1	39 ³¹ / ₃₂ "	24 ¹³ / ₁₆ "	19 ¹¹ / ₁₆ "	86

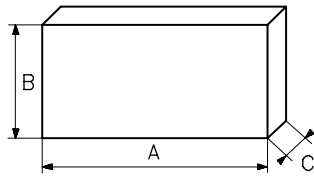

(B)

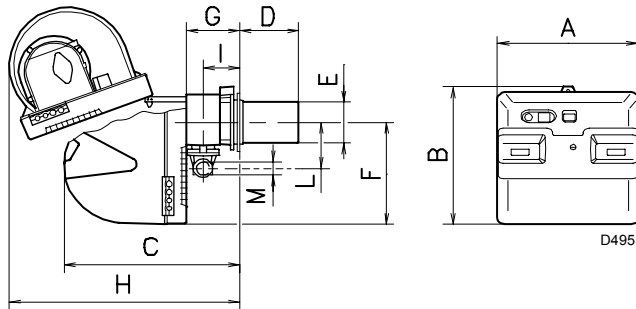

RS	A	B	C	D (1)	E	F	G	H	I	L	M
28/1	18 ²³ / ₃₂ "	18 ²¹ / ₃₂ "	22 ¹³ / ₁₆ "	8 1/2"-13 ¹³ / ₁₆ "	5 1/2"	13 ²⁷ / ₃₂ "	6 ⁷ / ₁₆ "	3 ¹⁷ / ₈ "	4 1/4"	6 ⁵ / ₈ "	1 1/2"
38/1	18 ²³ / ₃₂ "	18 ²¹ / ₃₂ "	22 ¹³ / ₁₆ "	8 1/2"-13 ¹³ / ₁₆ "	5 1/2"	13 ²⁷ / ₃₂ "	6 ⁷ / ₁₆ "	3 ¹⁷ / ₈ "	4 1/4"	6 ⁵ / ₈ "	1 1/2"

(1) Blast tube: short-long (obtainable with kit)

(C)

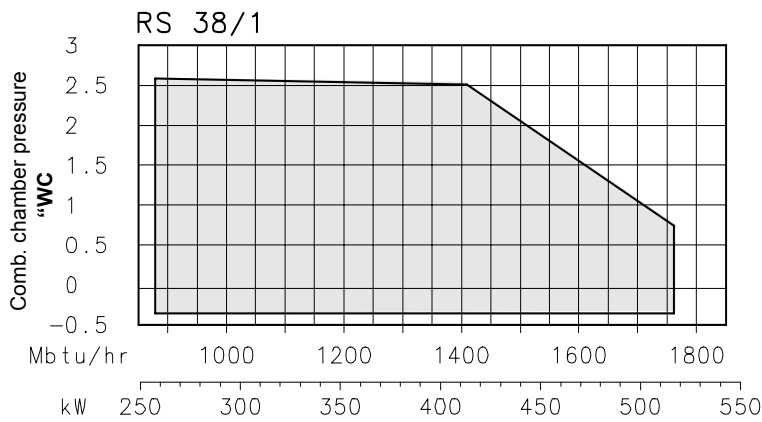
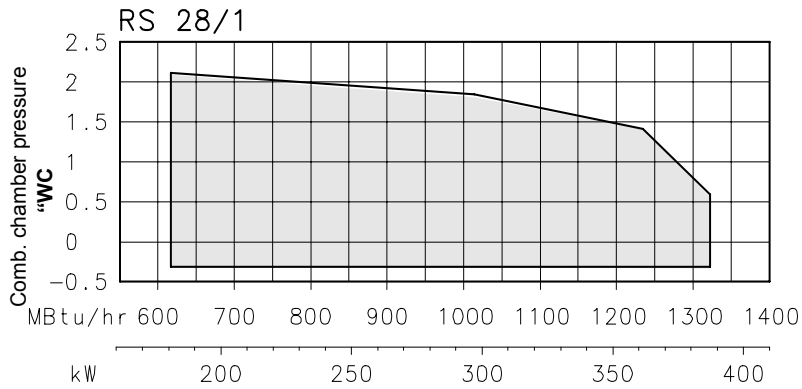

FIRING RATES (A)

The burner delivery must be selected within the area of the adjacent diagram.

Important:

the FIRING RATE value range has been obtained considering an ambient temperature of 68 °F (20 °C), and an atmospheric pressure of 394" WC and with the combustion head adjusted as shown on page 8.

Note:

The FIRING RATE areas given in figure (A) have been reduced by 10% with respect to the maximum range that can be reached.

Consult Appendix on page 18 for operation at different ambient temperatures and/or altitudes.

MINIMUM FURNACE DIMENSIONS (B)

The firing rates were set in relation to certified test boilers.

Figure (B) indicates the diameter and length of the test combustion chamber.

Example:

output 1388 MBtu/hr:
diameter 20 inch - length 4.9 ft.

(A) D2339

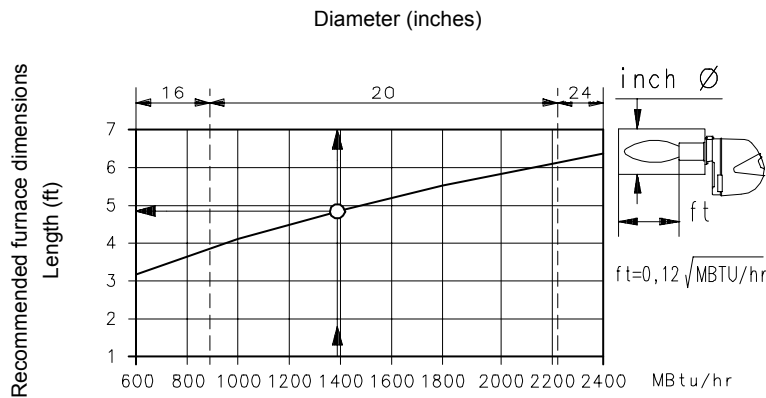

(B) D2918

RS 28/1

MBtu/hr	kW	Δp (" WC)
		1
625	183	0.98
699	205	1.22
795	233	1.57
891	261	1.85
986	289	2.17
1078	316	2.48
1174	344	2.76
1232	361	2.95
1320	387	3.43

RS 38/1

MBtu/hr	kW	Δp (" WC)
		1
871	255	1.02
986	289	1.22
1099	322	1.46
1211	355	1.69
1327	389	1.89
1440	422	2.13
1552	455	2.36
1665	488	2.6
1761	516	2.83

(A)

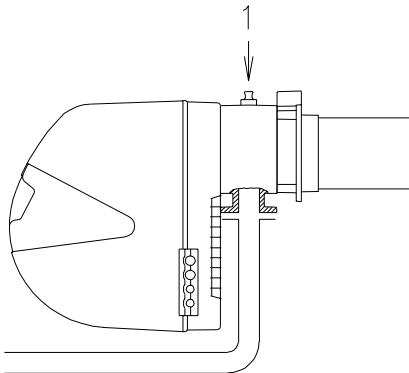

(B)

D2340

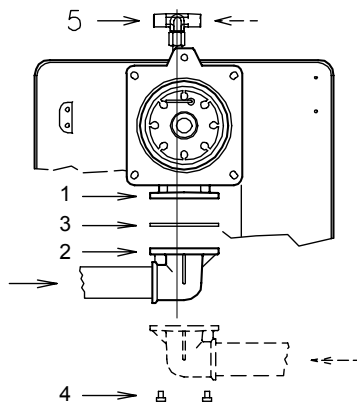

(C)

D2293

GAS PRESSURE

The adjacent tables are used to calculate manifold pressure taking into account combustion chamber pressure.

Column 1

Gas manifold pressure measured at test point 1)(B), with:

- Combustion chamber at 0" WC
- Gas ring 2)(B)p.8 adjusted as indicated in diagram (C)p.8.

Calculate the approximate output of the burner thus:

- subtract the combustion chamber pressure from the gas pressure measured at test point 1)(B).
- Find the nearest pressure value to your result in column 1 of the table for the burner in question.
- Read off the corresponding output on the left.

Example - RS 28/1:

- Natural gas
 - Gas ring 2)(B)p.8 adjusted as indicated in diagram (C)p.8.
 - Gas pressure at test point 1)(B) = 2.36" WC
 - Pressure in combustion chamber = 0.79" WC
- $2.36 - 0.79 = 1.57" \text{ WC}$

An output of 795 MBtu/hr shown in Table RS 28/1 corresponds to 1.57" WC pressure, column 1.

This value serves as a rough guide, the exact flow rate must be measured at the gas meter.

GAS PIPING

- The main gas train must be connected to the burner head 1)(C), using flange 2), gasket 3) and bolts 4) supplied with the burner.
- The gas train can enter the burner from the right or left side, depending on which is the most convenient, see fig.(C).
- Safety shut-off valves 8)-9)(B) must be as close as possible to the burner to ensure gas reaches the combustion head within the safety time range.
- The pilot gas train must be connected to the gas connection 5)(C) and can enter the burner from the right or left side.

inch	A	B	C
RS 28 /1	6 ⁹ / ₃₂ "	8 ¹³ / ₁₆ "	3/8 W
RS 38 /1	6 ⁹ / ₃₂ "	8 ¹³ / ₁₆ "	3/8 W

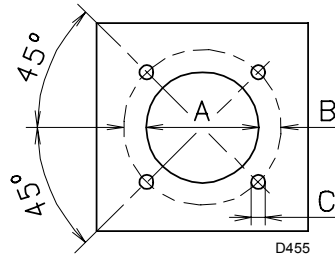

(A)

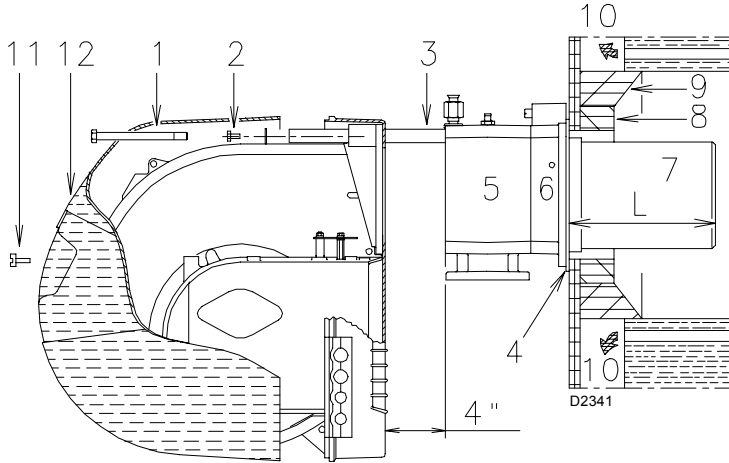

(B)

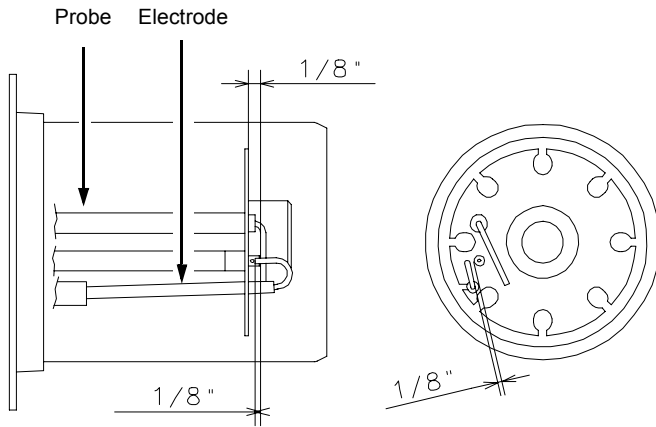

(C)

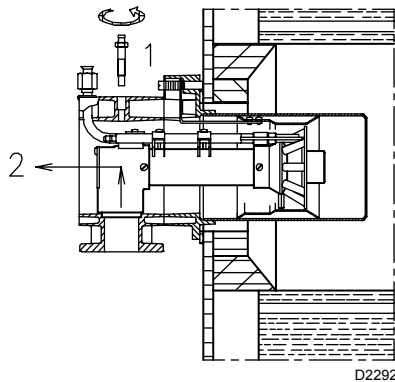

(D)

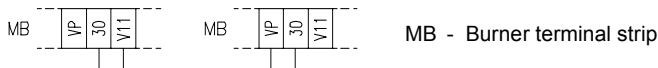

(E)

INSTALLATION

BOILER PLATE (A)

Drill the combustion chamber mounting plate as shown in (A). The position of the threaded holes can be marked using the burner head gasket supplied with the burner.

BLAST TUBE LENGTH (B)

The length of the blast tube must be selected according to the indications provided by the manufacturer of the boiler, and it must be greater than the thickness of the boiler door complete with its insulation.

The range of lengths available, L (inch), is as follows:

Blast tube 7):	RS 28/1	RS 38/1
• short	8 1/2"	8 1/2"
• long (with kit)	13 13/16"	13 13/16"

For boilers with front flue passes 10) or flame inversion chambers, protective insulation 8) must be inserted between the boiler refractory 9) and the blast tube 7).

This protective insulation must not compromise the extraction of the blast tube.

For boilers having a water-cooled front the insulation 8)-9)(B) is not required unless it is required by the boiler manufacturer.

SECURING THE BURNER TO THE BOILER (B)

Before securing the burner to the boiler, check through the blast tube opening to make sure that the flame rod (probe) is correctly set in position, as shown in (C).

Now detach the combustion head from the burner, fig.(B):

- remove screw 11) and withdraw the cover 12)
- Remove the screws 2) from the slide bars 3)
- Remove screw 1) and pull the burner back on slide bars 3) by about 4".

Disconnect the wires from the probe and the electrode and then pull the burner completely off the slide bars, after removing the split pin from the slide bar 3).

Secure the flange 6)(B) to the boiler plate, inserting the gasket 4)(B). Use the 4 screws, also supplied with the unit, after first protecting the thread with an anti-seize product.

The seal between burner and boiler must be airtight.

If you noticed any irregularities in positions of the probe or ignition electrode during the check mentioned above, remove screw 1)(D), extract the internal part 2)(D) of the head and proceed to set up the two components correctly.

IGNITION PILOT ADJUSTMENT

Place the pilot and electrode as shown in fig. (C). The pilot works correctly at pressures ranging from 5 - 12" WC.

Important

To set the pilot without main burner operation, proceed as follows:

- Move the jumper from terminals "30-V11" to terminals "30-VP", as given in fig. (E), this way the main valve is cut out.
- With the burner in the manual position, hold the air damper in the minimum position and make the setting.
- When the setting is correct, replace the jumper on "30-V11".

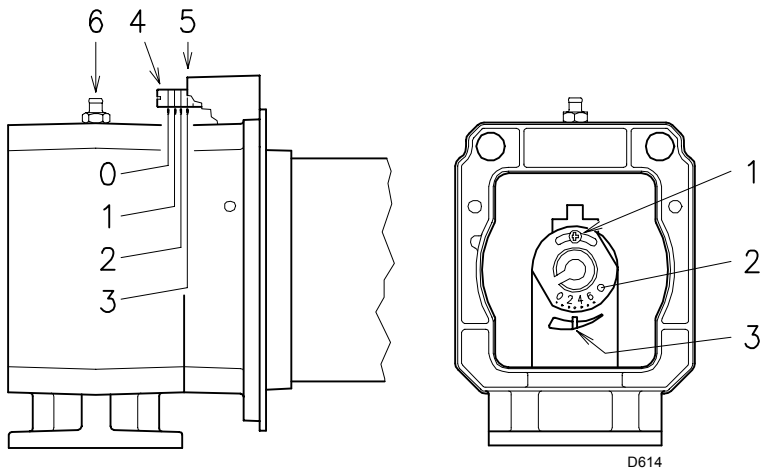

(A) (B)

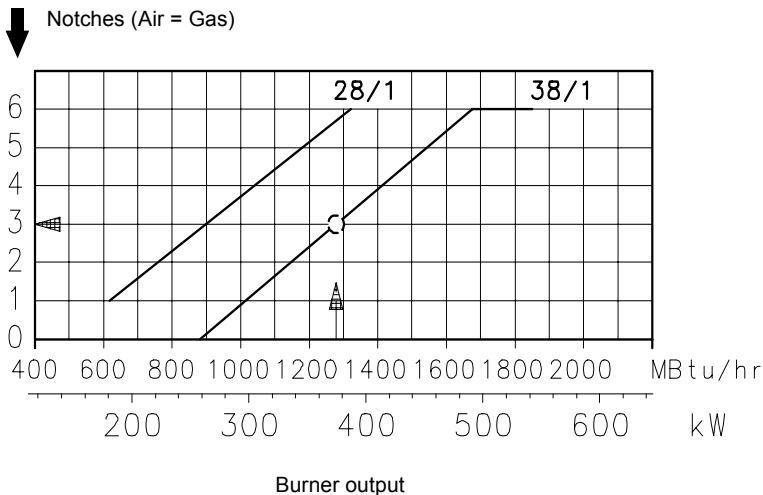

(C) D2343

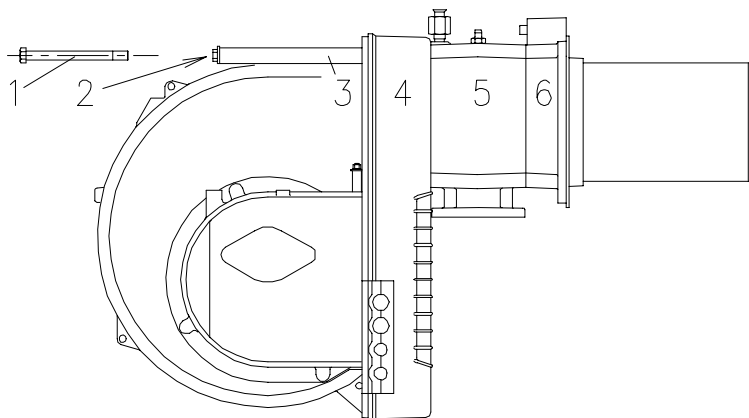

(D) D2344

COMBUSTION HEAD ADJUSTMENT

(For PROPANE operation see page 14).

Installation operations are now at the stage where the blast tube and sleeve are secured to the boiler as shown in fig.(A). It is now a very simple matter to set up the combustion head, as this depends solely on the output developed by the burner.

It is therefore essential to establish this value before proceeding to set up the combustion head. There are two adjustments to make on the head: Air and gas .

In diagram (C) find the notch to use for adjusting the air and the gas, and then proceed as follows:

Air adjustment (A)

Turn screw 4)(A) until the notch identified is aligned with the front surface 5)(A) of the flange.

Gas adjustment (B)

Loosen screws 1)(B) and turn ring 2) until the notch identified is aligned with index 3).

Tighten the screw 1) fully down.

Example RS 38/1:

burner output = 1276 MBtu/hr.

If we consult diagram (C) we find that for this output, air and gas must be adjusted using notch 3, as shown in figs. (A) and (B).

Note

Diagram (C) shows the ideal settings for the combustion head. If the gas mains pressure is too low to reach the pressure indicated on page 6, and if the ring 2)(B) is not fully open, it can be opened wider by 1 or 2 notches.

Continuing with the previous example, page 6 indicates that for burner RS 38/1 with output of 1276 MBtu/hr (374 kW) a pressure of approximately 1.8" WC is necessary at test point 6)(A). If this pressure cannot be reached, open the ring 2)(B) to notch 4 or 5.

Make sure that the combustion characteristics are satisfactory and free of pulsations.

Once you have finished setting up the head, refit the burner 4)(D) to the slide bars 3) at approximately 4" from the sleeve 5) - burner positioned as shown in fig.(B)p.7 - insert the flame detection probe (flame rod) cable and the ignition electrode cable and then slide the burner up to the sleeve so that it is positioned as shown in fig.(D).

Refit screws 2) on slide bars 3).

Secure the burner to the sleeve by tightening screw 1) and then refit the split pin into one of two slide bars 3).

Connect gas train and pilot train as shown in fig. (C) page 6.

Important

When fitting the burner on the two slide bars, it is advisable to gently draw out the high tension cable and flame rod cable until they are slightly stretched.

TYPICAL UL SCHEMATIC GAS PIPING

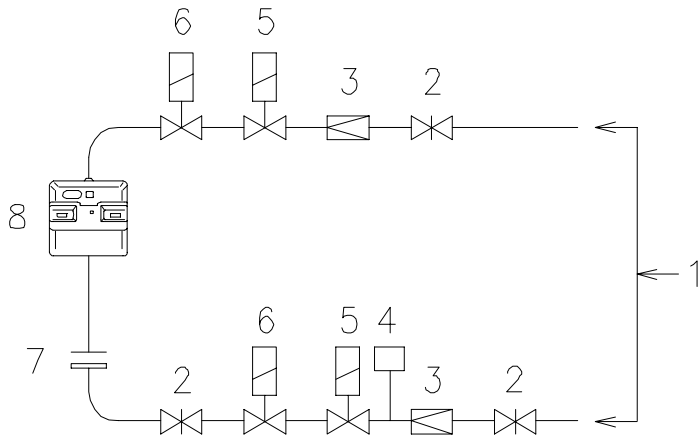

(A)

D2345

GAS PIPING

KEY (A)

- 1 - Gas input pipe
- 2 - Manual valve
- 3 - Pressure regulator
- 4 - Low gas pressure switch
- 5 - 1st gas safety shut off valve
- 6 - 2nd safety shut off valve
- 7 - Standard issue burner gasket with flange
- 8 - Burner

Note

See the accompanying instructions for the adjustment of the gas train.

LOW GAS PRESSURE SWITCH

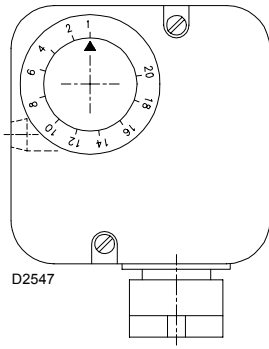

(A)

AIR PRESSURE SWITCH

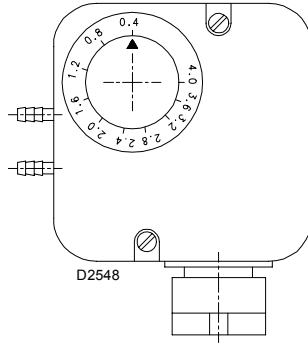

(B)

ADJUSTMENTS BEFORE FIRST FIRING

Adjustment of the combustion head, and air and gas deliveries has been illustrated on page 8.

In addition, the following adjustments must also be made:

- Open manual valves on the gas train.
 - Adjust the low gas pressure switch to the start of the scale (A).
 - Adjust the air pressure switch to the zero position of the scale (B).
 - Purge the air from the gas line.
 - Fit a U-type manometer (C) to the gas pressure test point on the sleeve.
- The manometer readings are used to calculate burner input using the tables on page 6.
- Fan air damper: leave at the factory setting.

Before starting up the burner it is good practice to adjust the gas train so that ignition takes place in conditions of maximum safety, i.e. with gas delivery at the minimum.

BURNER STARTING

Close the control circuit.

As soon as the burner starts check the direction of rotation of the fan blade, looking through the flame inspection window 18)(A)p.4.

BURNER FIRING

Having completed the checks indicated in the previous heading, the burner pilot should fire. If the motor starts but the flame does not appear and the flame safeguard goes into lock-out, reset and wait for a new firing attempt.

Pilot adjustment has been illustrated on page 7.

Having adjusted the pilot, reconnect the main valve and ignite the main flame.

Once the burner has fired, now proceed with set up.

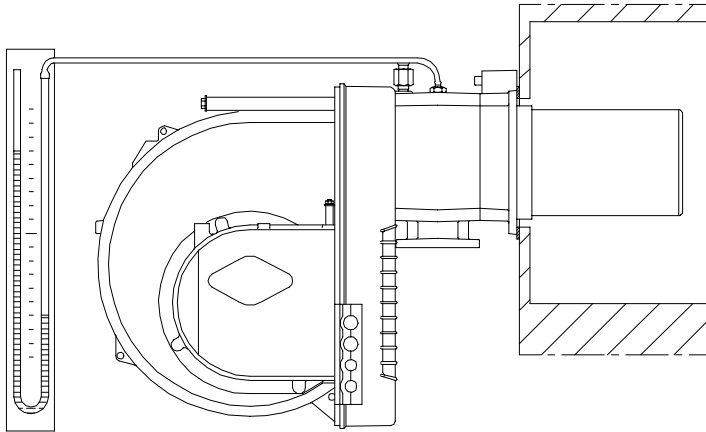

(C)

D2346

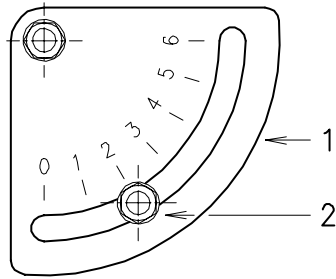

(A)

D593

BURNER CALIBRATION

The optimum calibration of the burner requires an analysis of the flue gases at the boiler outlet.

Adjust successively:

- 1 - First firing output
- 2 - Maximum output of the burner
- 3 - Air pressure switch
- 4 - Low gas pressure switch

1 - FIRING OUTPUT

Pilot adjustment has been illustrated on page 7.

2 - MAXIMUM OUTPUT

The maximum output of the burner must be set within the firing rate range shown on page 5.

Adjusting gas delivery

Measure the gas delivery at the meter.

A guideline indication can be calculated from the tables on page 6, simply read off the gas pressure on the U-type manometer, see fig.(C) on page 10, and follow the instructions on page 6.

- If delivery needs to be reduced, reduce outlet gas pressure and, if it is already very low, slightly close adjustment valve (if installed).
- If delivery needs to be increased, increase outlet gas pressure.

Adjusting air delivery

Adjust the fan air damper by using the indexed selector 1)(A) after having loosened the nut 2)(A).

AIR PRESSURE SWITCH

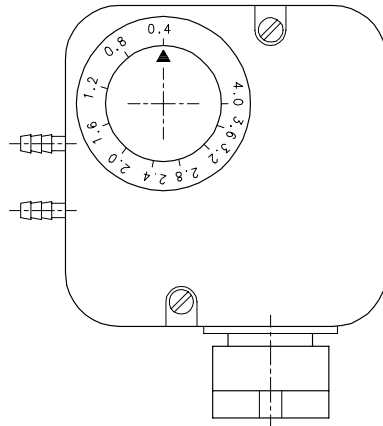

(A)

D2548

LOW GAS PRESSURE SWITCH

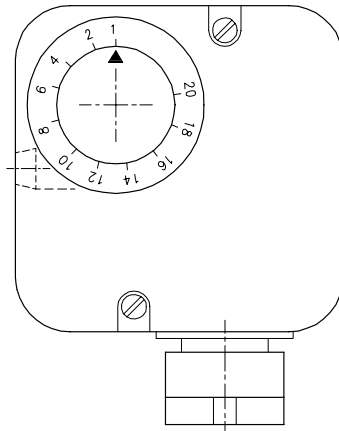

(B)

D2547

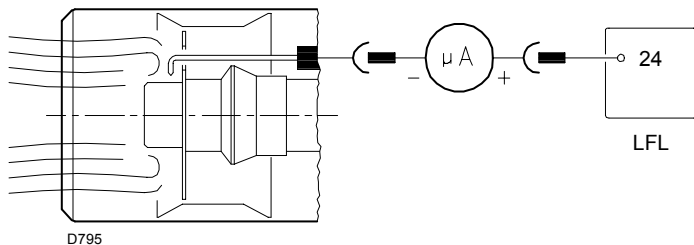

D795

(C)

3 - AIR PRESSURE SWITCH (A)

Adjust the air pressure switch after having performed all other burner adjustments with the air pressure switch set to the start of the scale (A).

With the burner operating, increase adjustment pressure by slowly turning the relative dial clockwise until the burner locks out.

Then turn the dial anti-clockwise by about 20% of the set point and repeat burner starting to ensure it is correct.

If the burner locks out again, turn the dial anti-clockwise a little bit more.

Attention: As a rule, the air pressure switch must prevent the formation of CO.

To check this, insert a combustion analyser into the chimney, slowly close the fan suction inlet (for example with cardboard) and check that the burner locks out, before the CO in the fumes exceeds 400 ppm.

The air pressure switch may operate in "differential" operation in two pipe system. If a negative pressure in the combustion chamber during pre-purging prevents the air pressure switch from switching, switching may be obtained by fitting a second pipe between the air pressure switch and the suction inlet of the fan. In this way the air pressure switch operates as differential pressure switch.

4 - LOW GAS PRESSURE SWITCH (B)

Adjust the low gas pressure switch after having performed all the other burner adjustments with the pressure switch set at the start of the scale (B).

With the burner operating, increase adjustment pressure by slowly turning the relative dial clockwise until the burner locks out.

Then turn the dial anti-clockwise by 0.8" WC and repeat burner starting to ensure it is uniform.

If the burner locks out again, turn the dial anti-clockwise again by 0.4" WC.

FLAME PRESENT CHECK (C)

The burner is fitted with an ionisation (flame rod) system which ensures that a flame is present. The minimum current for plant operation is 6 μA (see manufacturers specifications).

The burner provides a much higher current, so that controls are not normally required. However, if it is necessary to measure the ionisation current, disconnect the plug-socket 23)(A)p.4 on the ionisation probe cable and insert a direct current microammeter with a base scale of 100 μA.

Carefully check polarities!

FLAME INSPECTION WINDOW

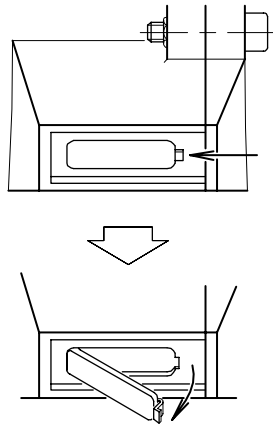

(A)

D484

OPENING THE BURNER

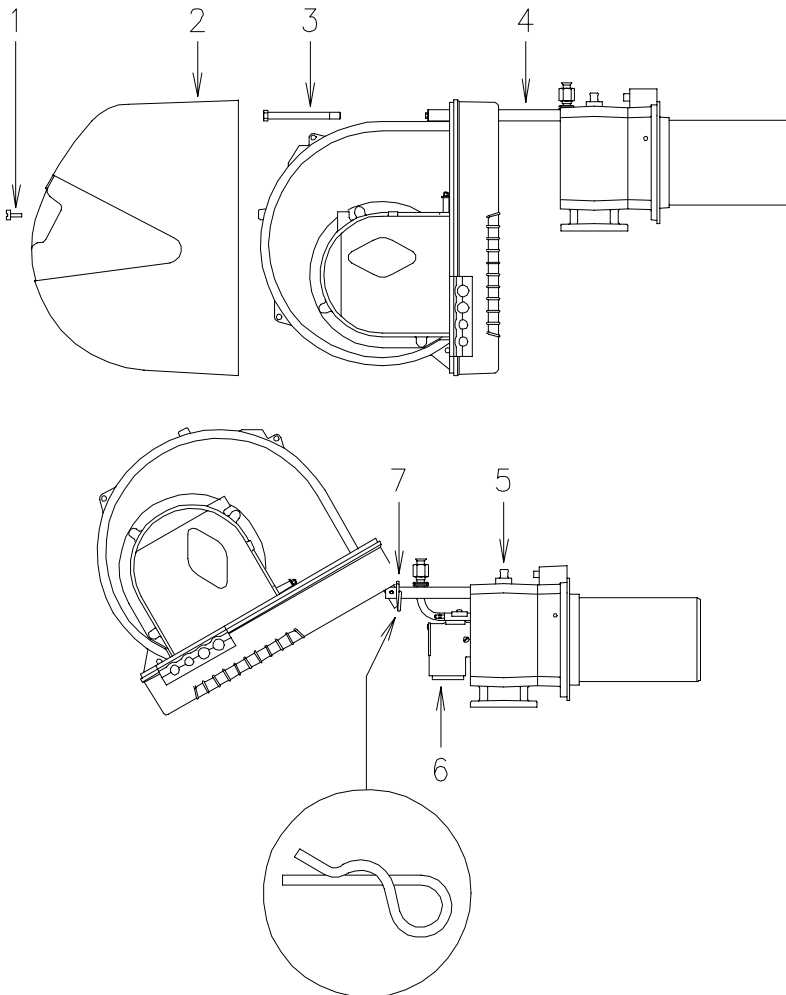

(B)

D2348

MAINTENANCE

Combustion

The optimum calibration of the burner requires an analysis of the flue gases. Significant differences with respect to the previous measurements indicate the points where more care should be exercised during maintenance.

Gas leaks

Make sure that there are no gas leaks on the pipework between the gas meter and the burner.

Flame inspection window

Clean the flame inspection window (A).

Combustion head

Open the burner and make sure that all components of the combustion head are in good condition, not deformed by the high temperatures, free of impurities from the surroundings and correctly positioned. If in doubt, disassemble the elbow fitting 6)(B).

Burner

Check that the graduated sector that controls the air damper is secured by the nut 2)(A)p.11.

The tightness of the screws that fasten the cables to the burner terminal strip must also be checked.

Clean the outside of the burner.

Combustion

Adjust the burner if the combustion values found at the beginning of the operation do not comply with the regulations in force, or do not correspond to good combustion. Record the new combustion values; they will be useful for subsequent set up.

TO OPEN THE BURNER (B):

- switch off the electrical power.
- Remove screw 1) and withdraw cover 2).
- Remove screw 3), the split pin 7) and pull the burner back by about 4" on the slide bars 4). Disconnect the probe and electrode leads and then pull the burner fully back.
- Turn the burner as shown in the figure and fit the split pin 7) into one of the slide bar holes so that the burner remains in position.

Now extract the gas distributor 6) after having removed the screw 5) and disconnecting the pilot gas line.

TO CLOSE THE BURNER (B):

- remove the split pin 7) and push the burner until it is about 4" from the sleeve.
- Re-connect the leads and slide in the burner until it comes to a stop.
- Refit screw 3), the split pin 7) and pull the probe and electrode leads gently out until they are slightly stretched.
- Connect the pilot gas line.

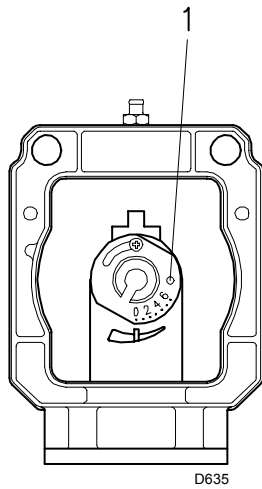
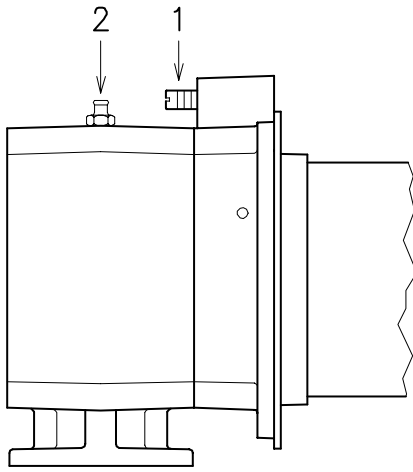

PROPANE OPERATION

The RS 28/1 and 38/1 Models burners can be operated on both natural gas and propane.

FIRING RATE

It is the same as the one calculated for natural gas, see page 5.

SETTING THE COMBUSTION HEAD

Adjusting air delivery

Adjust the screw 1)(A) as was done for natural gas, according to the burner output, see page 8.

Gas calibration

Adjust the ring 1)(B) always to the zero position, as shown in Fig.(B), whatever the burner output is.

GAS PRESSURE

The tables (C) are used to calculate manifold pressure taking into account combustion chamber pressure.

Column 1

Gas manifold pressure measured at test-point 1)(B), with the:

- Combustion chamber at 0" WC
- Gas ring 1)(B) set to zero.

(A)

(B)

RS 28/1

MBtu/hr	kW	Δp (" WC)
		1
625	183	0.47
699	205	0.67
795	233	0.87
891	261	1.06
986	289	1.26
1078	316	1.50
1174	344	1.69
1232	361	1.85
1320	387	2.09

RS 38/1

MBtu/hr	kW	Δp (" WC)
		1
871	255	0.51
986	289	0.75
1099	322	0.98
1211	355	1.26
1327	389	1.50
1440	422	1.73
1552	455	1.97
1665	488	2.17
1761	516	2.28

(C)

APPENDIX

Electrical connections



NOTES

The electrical wirings must be carried out in conformity with the regulations in force in the countries of destination, and by qualified personnel.

Riello S.p.A. cannot accept any responsibility for modifications or connections other than those shown in these diagrams.

RS 28/1 - 38/1		
120V		
	RS 28/1	RS 38/1
FU1 (A)	T10	T10
FU2 (A)	T6	

NOTES

Field Wiring Connections

- The RS 28/1 - 38/1 burners have been type- approved for intermittent operation. This means they should compulsorily be stopped at least once every 24 hours to enable the flame safeguard to check its own efficiency at start-up. Burner halts are normally provided for automatically by the boiler load control system.

If this is not the case, a time switch should be fitted in series to IN to provide for burner shut-down at least once every 24 hours.



Important note

When installing for the first time and after any maintenance work, make sure the gas valves are connected properly to the orange terminals before proceeding to ignite the burner. Insert auxiliary lamps or check, with the aid of a tester, that power is not being supplied to the valves during standby or pre-purging. Burner ignition with the gas valves open during pre-purging may cause the generator to burst.

- Do not invert the neutral with the phase wire in the electricity supply line.
- Only use original spare parts to replace the components.

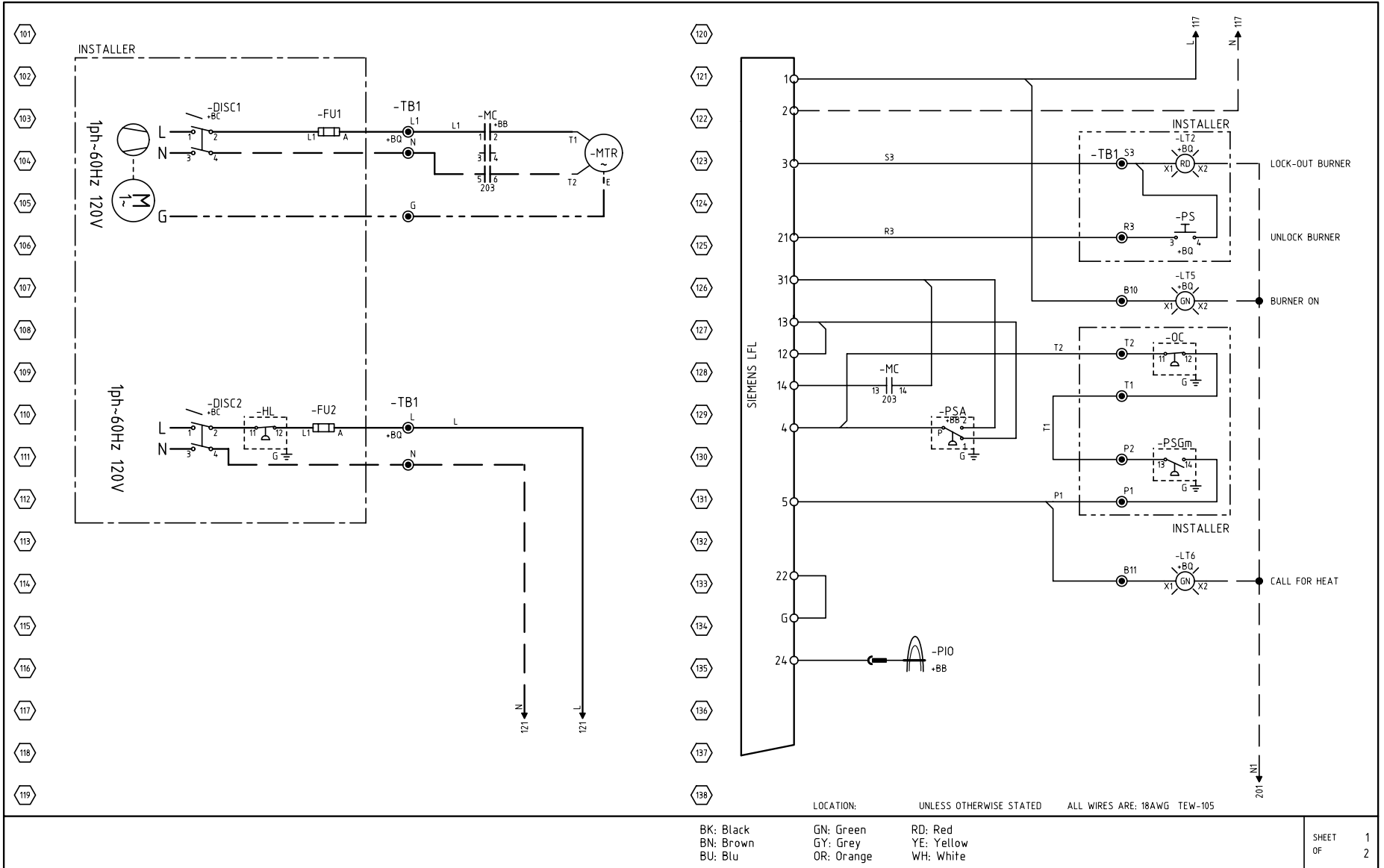

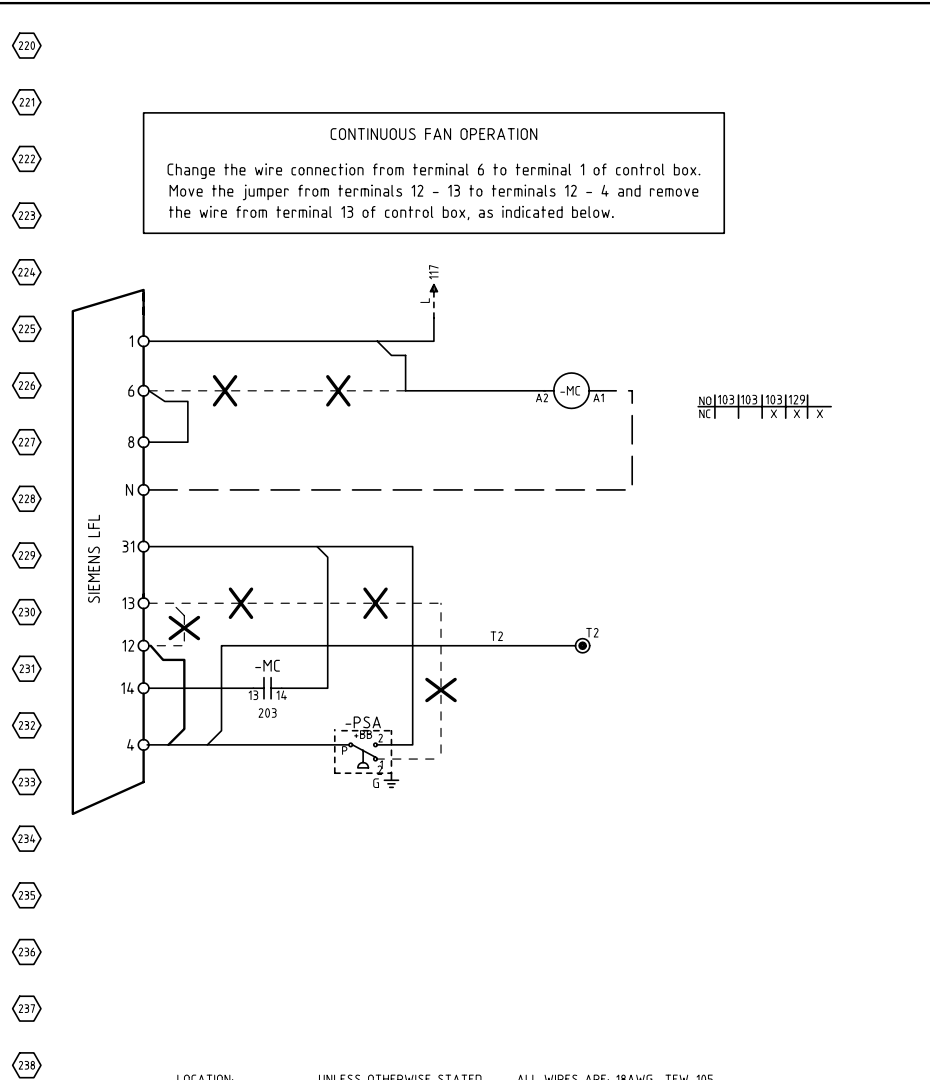
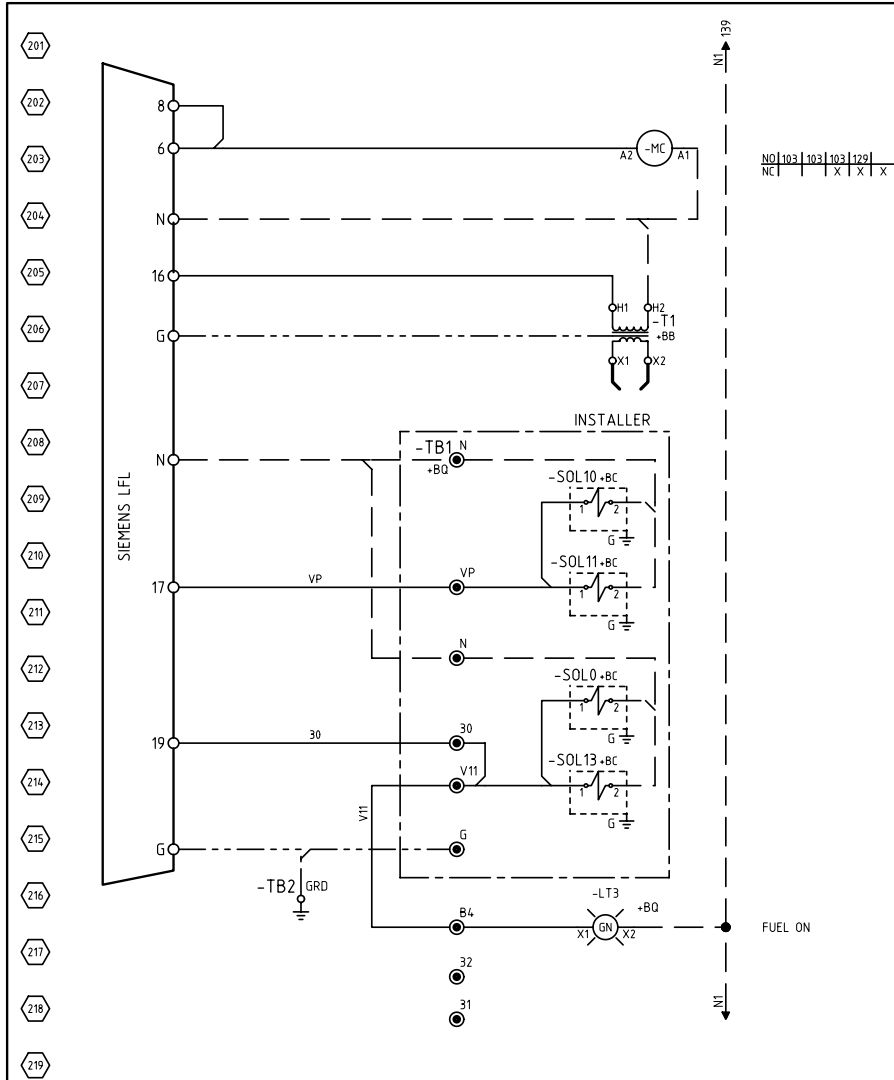

CONTINUOUS FAN OPERATION

Change the wire connection from terminal 6 to terminal 1 of control box. Move the jumper from terminals 12 - 13 to terminals 12 - 4 and remove the wire from terminal 13 of control box, as indicated below.

LOCATION: UNLESS OTHERWISE STATED ALL WIRES ARE: 18AWG TEW-105

BK: Black GN: Green RD: Red
 BN: Brown GY: Grey YE: Yellow
 BU: Blue OR: Orange WH: White

SHEET 2
 OF 2

APPENDIX - Burner firing rates according to air density

above sea level		average barom. pressure		CORRECTION FACTOR F								
				Air temperature °F (°C)								
ft	m	" W.C.	mbar	0 (0°C)	41 (5°C)	50 (10°C)	59 (15°C)	68 (20°C)	77 (25°C)	86 (30°C)	104 (40°C)	
0	0	399	1013	1,087	1,068	1,049	1,031	1,013	0,996	0,980	0,948	
329	100	394	1000	1,073	1,054	1,035	1,017	1,000	0,983	0,967	0,936	
658	200	389	989	1,061	1,042	1,024	1,006	0,989	0,972	0,956	0,926	
987	300	385	978	1,050	1,031	1,013	0,995	0,978	0,962	0,946	0,916	
1316	400	380	966	1,037	1,018	1,000	0,983	0,966	0,950	0,934	0,904	
1645	500	376	955	1,025	1,007	0,989	0,972	0,955	0,939	0,923	0,894	
1974	600	372	944	1,013	0,995	0,977	0,960	0,944	0,928	0,913	0,884	
2303	700	367	932	1,000	0,982	0,965	0,948	0,932	0,916	0,901	0,872	
2632	800	363	921	0,988	0,971	0,954	0,937	0,921	0,906	0,891	0,862	
2961	900	358	910	0,977	0,959	0,942	0,926	0,910	0,895	0,880	0,852	
3290	1000	354	898	0,964	0,946	0,930	0,914	0,898	0,883	0,868	0,841	
3947	1200	346	878	0,942	0,925	0,909	0,893	0,878	0,863	0,849	0,822	
4605	1400	337	856	0,919	0,902	0,886	0,871	0,856	0,842	0,828	0,801	
5263	1600	329	836	0,897	0,881	0,866	0,851	0,836	0,822	0,808	0,783	
5921	1800	321	815	0,875	0,859	0,844	0,829	0,815	0,801	0,788	0,763	
6579	2000	313	794	0,852	0,837	0,822	0,808	0,794	0,781	0,768	0,743	

(A)

The FIRING RATE area values have been obtained considering a surrounding temperature of 68°F (20°C), and an atmospheric pressure of 398" W.C. and with the combustion head adjusted as shown on page 8.

The burner may be required to operate with combustion air at a higher temperature and/or at higher altitudes.

Heating of air and increase in altitude produce the same effect: the expansion of the air volume, i.e. the reduction of air density.

The burner fan's delivery remains substantially the same, but the oxygen content per cubic meter and the fan's head are reduced.

It is therefore important to know if the maximum output required of the burner at a given combustion chamber pressure remains within the burner's firing rate range even at different temperature and altitude conditions. Proceed as follows to check the above:

- 1 - Find the correction factor F in the Table (A) for the plant's air temperature and altitude.
- 2 - Divide the burner's delivery Q by F in order to obtain the equivalent delivery Q_e:

$$Q_e = Q : F \quad (\text{MBtu/hr})$$

- 3 - In the firing rate range of the burner, Fig. (B), indicate the work point defined by:

Q_e = equivalent delivery

H1 = combustion chamber pressure

The resulting point A must remain within the firing rate range.

- 4 - Plot a vertical line from Point A as shown in Figure (B) and find the maximum pressure H2 of the firing rate.

- 5 - Multiply H2 by F to obtain the maximum reduced pressure H3 of the firing rate.

$$H_3 = H_2 \times F \quad (\text{" W.C.})$$

If H3 is greater than H1, as shown in Fig. (B), the burner delivers the output required.

If H3 is lower than H1, the burner's delivery must be reduced. A reduction in delivery is accompanied by a reduction of the pressure in the combustion chamber:

Q_r = reduced delivery

H1_r = reduced pressure

$$H_{1r} = H_1 \times \left(\frac{Q_r}{Q} \right)^2$$

Example, a 5% delivery reduction:

$$Q_r = Q \times 0.95$$

$$H_{1r} = H_1 \times (0.95)^2$$

Steps 2 - 5 must now be repeated using the new Q_r and H1_r values.

Important: the combustion head must be adjusted in respect to the equivalent delivery Q_e.

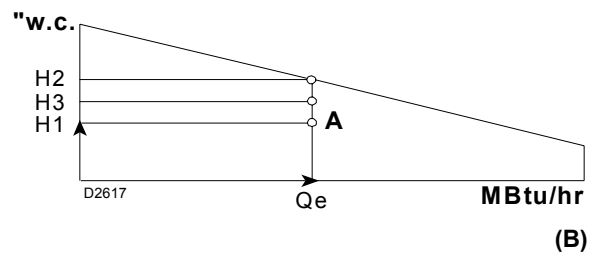

(B)

BURNER OPERATION

BURNER STARTING

Control device closes.

Fan motor starts.

The air damper is set on maximum adjustment output. The pre-purge stage follows.

Ignition electrode strikes a spark.

Pilot valve opens. The pilot flame is ignited.

After about 12s the main flame ignites and starting cycle ends.

STEADY STATE OPERATION

At the end of the starting cycle, the flame safeguard continues to check that the flame is present and that the air and gas pressure switches are in the correct position.

The burner continues to operate at constant output. If the temperature or pressure in the boiler continues to rise, and opens load control, the burner will stop.

LFL 1.335 Series 01

t1	30s	t5	61s
t2	4s	t6	16s
t3	2s	t7	4s
t4	12.5s	t8	12.5s

Legend for the times

- t1** Purge time
- t2** Safety time
- t3** Pre-ignition time, short (ignition transformer on terminal 16)
- t4** Interval between start of t2 and release of valve at terminal 19
- t5** Duration of startup sequence
- t6** Running time of pilot
- t7** Second safety time with burners using pilot
- t8** Permissible after-burn time

FIRING FAILURE

If the burner does not fire, it locks out within 2.5 seconds from opening the pilot valve and then within 5 seconds from opening the main valves.

BURNER FLAME GOES OUT DURING OPERATION

If the flame should accidentally go out during operation, the burner will lock out within 1s.

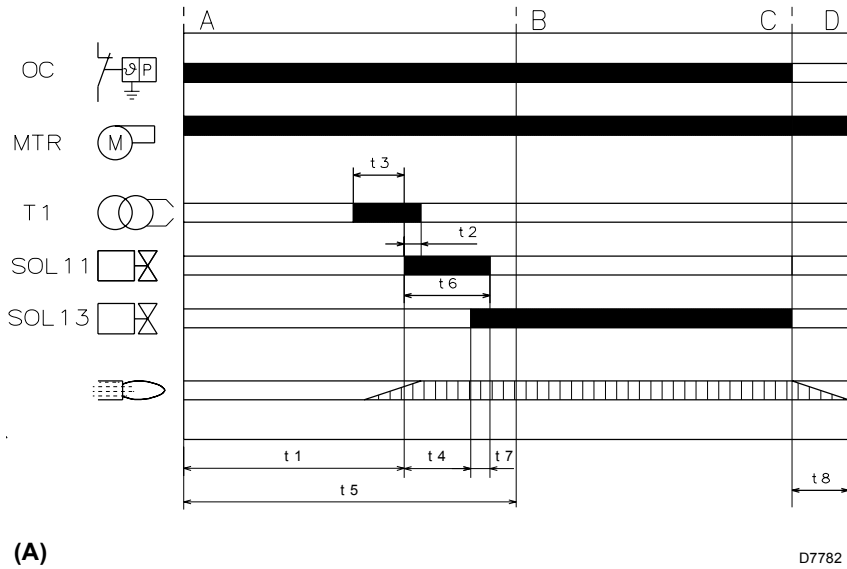

BURNER FAULTS

Control program under fault conditions and lock-out indication

In case of any disturbance, the sequence mechanism stops and with it the lock-out indicator. The symbol above the reading mark of the indicator gives the type of disturbance:



No start, e.g. because one contact is not closed. Lock-out during or after control program sequence due to extraneous light (e.g. non-extinguished flames, leaking fuel valves, defects in the flame supervision circuit, etc.)



Interruption of startup sequence, because the OPEN signal has not been delivered to terminal 8 by limit switch "a". Terminals 6, 7 and 14 remain under voltage until the fault has been corrected!



Lockout, because there is no air pressure indication at the beginning of air pressure control. **Every air pressure failure after this moment in time leads to lock-out, too!**



Lock-out due to a fault in the flame supervision circuit.



Interruption of startup sequence, because the position signal for the low-flame position has not been delivered to terminal 8 by auxiliary switch "m". Terminals 6, 7 and 14 remain under voltage until the fault has been corrected!



Lock-out, because no flame signal is present after completion of the (1st) safety time.



Lock-out, because no flame signal has been received on completion of the 2nd safety time (flame signal of the main flame with interrupted pilot burners).



Lock-out, because the flame signal has been lost during burner operation.

If lock-out occurs at any other moment in time between the start and the pre-ignition which is not marked by a symbol, this is usually caused by a premature, i.e. faulty flame signal, e.g. caused by a self-igniting UV tube.

Key to Layouts

- + BB** - Components on board burners
- + BQ** - Components on board main panel
- + BC** - Components on board boiler
- DISC1** - Disconnect switch motor
- DISC2** - Disconnect switch auxiliary
- FU1** - Motor fuse
- FU2** - Auxiliary fuse
- HL** - High limit control
- LFL** - Control box
- LT2** - Remote lock-out signal
- LT3** - Fire signal
- LT5** - Power on signal
- LT6** - Limit satisfied
- MC** - Motor contactor
- MTR** - Fan motor
- OC** - Operating control
- PIO** - Ionisation probe (flame rod)
- PS** - Remote lock-out reset
- PSA** - Air pressure switch
- PSGm** - Min. gas pressure switch
- SOL0** - Safety solenoid valve
- SOL10** - Pilot valve
- SOL11** - Adjustment valve
- SOL13** - Pilot valve (safety)
- T1** - Ignition transformer
- TB1** - Burner terminal strip
- TB2** - Burner ground (earth) connection

BURNER START UP REPORT

Model number: _____	Serial number: _____
Project name: _____	Start-up date: _____
Installing contractor: _____	Phone number: _____

GAS OPERATION			
Gas Supply Pressure: _____	CO ₂ : Low Fire _____	High Fire _____	
Main Power Supply: _____	O ₂ : Low Fire _____	High Fire _____	
Control Power Supply: _____	CO: Low Fire _____	High Fire _____	
Burner Firing Rate: _____	NO _x : Low Fire _____	High Fire _____	
Manifold Pressure: _____	Net Stack Temp - Low Fire: _____	High Fire: _____	
Pilot Flame Signal: _____	Comb. Efficiency - Low Fire: _____	High Fire: _____	
Low Fire Flame Signal: _____	Overfire Draft: _____		
High Fire Flame Signal: _____			

OIL OPERATION			
Oil supply pressure: _____	CO ₂ : Low Fire _____	High Fire _____	
Oil suction pressure: _____	O ₂ : Low Fire _____	High Fire _____	
Control Power Supply: _____	CO: Low Fire _____	High Fire _____	
Burner Firing Rate: _____	NO _x : Low Fire _____	High Fire _____	
Low Fire Flame Signal: _____	Net Stack Temp - Low Fire: _____	High Fire: _____	
High Fire Flame Signal: _____	Comb. Efficiency - Low Fire: _____	High Fire: _____	
Low Fire Nozzle Size: _____	Overfire Draft: _____		
High Fire Nozzle Size: _____	Smoke number: _____		

CONTROL SETTINGS			
Operating Setpoint: _____	Low Oil Pressure: _____		
High Limit Setpoint: _____	High Oil Pressure: _____		
Low Gas Pressure: _____	Flame Safeguard Model Number: _____		
High Gas Pressure: _____	Modulating Signal Type: _____		

NOTES _____ _____ _____ _____
--



RIELLO S.p.A.
I - 37045 Legnago (VR)
Tel.: +39.0442.630111
[http:// www.rielloburners.com](http://www.rielloburners.com)



35 Pond Park Road
Hingham, Massachusetts,
U.S.A. 02043

RIELLO BURNERS NORTH AMERICA

1-800-4-RIELLO

1-800-474-3556

<http://www.riello-burners.com>

2165 Meadowpine Blvd.
Mississauga, Ontario,
Canada L5N 6H6