

Specification Data

1	F	15.1	Rev. 16
1-03	Replaces	4-01	

TYPE F TURBO-RING FORCED DRAFT BURNERS

Patented*

USING GAS AND LIGHT OIL MECHANICAL PRESSURE, AIR OR STEAM ATOMIZATION

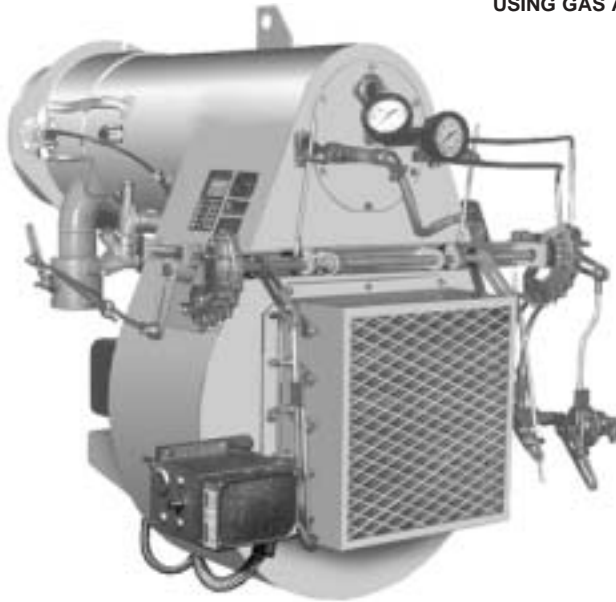

TYPICAL DUAL-FUEL BURNER WITH GAS AND PRESSURE ATOMIZING OIL SYSTEM

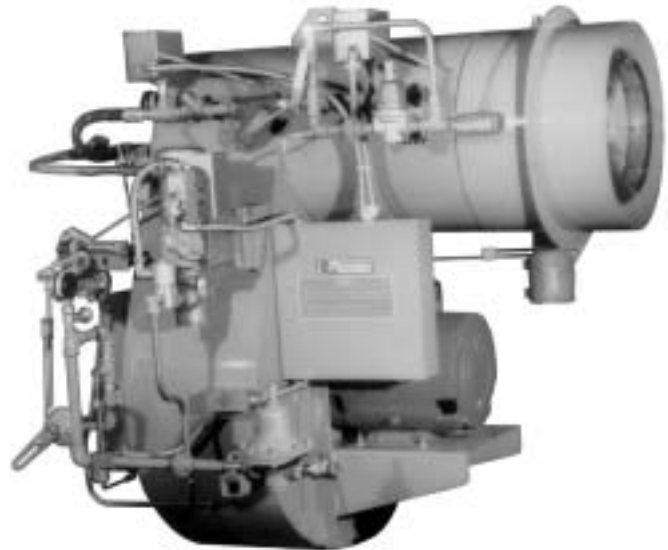

TYPICAL DUAL-FUEL BURNER WITH GAS AND AIR, OR STEAM ATOMIZING OIL SYSTEM

NOTE

Air compressor is standard with air atomizing systems only. It is optional (extra cost) for steam atomizing units. Oil, gas and air pressure gauges are optional.

Burner Numbering System

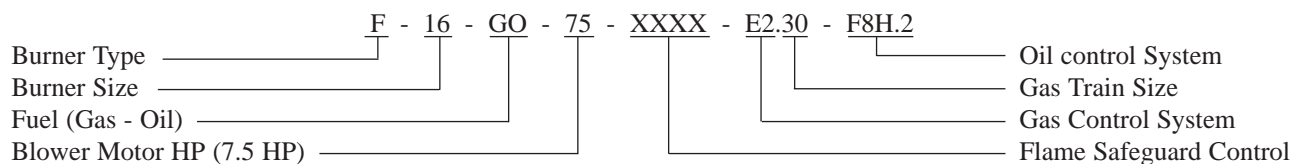

- 1 See Catalog Sheet 1-gen-10.1 for burner numbering.
- 2 Use Order Entry and Equipment Pricing Form 1196 when placing order.
- 3 See Catalog Sheet 1-F-15.16 for F22 burner.

*Covered by one or more of the following patents:
U.S. patent numbers 4785680; 4932274; 5441404;
5722821; 5944506; 5957682. Canadian patent
number 1279632 and Canadian patents pending.

Specifications and Capacities

BASIC BURNER MODEL NO.	MAXIMUM FIRING RATE COMBUSTION CHAMBER PRESSURE									BURNER	MECHANICAL PRESS. ATOMIZATION AT 300 PSIG		AIR ATOMIZATION	
	DRAFT-.05" W.C.			LOW PRESSURE			HIGH PRESSURE			BLOWER	BURNER OIL PUMP SET		AIR COMPRESSOR	
	NATURAL GAS	OIL	PRESS.	NATURAL GAS	OIL	PRESS.	NATURAL GAS	OIL	MOTOR					
	BTU/HR 1000s	GPH	INCHES W.C.	BTU/HR 1000s	GPH	INCHES W.C.	BTU/HR 1000s	GPH	HP @ 3450 RPM	MODEL NO.	HP @ 1725 RPM	MODEL NO.	HP @ 1725 RPM	
F10 15	3650	26	0.5	3360	24	-	-	-	1-1/2	HS2D-60	1/2	LE15	2	
F10 30	4750	34	-	-	-	-	-	-	3	HS2D-60	1/2	LE15	2	
F10.1 30	-	-	0.5	4400	31	1.3	4200	30	3	HS2D-60	1/2	LE15	2	
F10.1 50	6050	43	-	-	-	-	-	-	5	HS2D-60	1/2	LE15	2	
F10.2 50	-	-	0.5	5500	39	-	-	-	5	HS2D-60	1/2	LE15	2	
F12.9 30	7000	50	-	-	-	-	-	-	3	HS2D-80	1/2	LE15	2	
F12 30	-	-	0.5	6300	45	1.5	5600	40	3	HS2D-80	1/2	LE15	2	
F12 50	8400	60	-	-	-	-	-	-	5	HS2D-95	3/4	LE22	3	
F12.1 50	-	-	0.5	7700	55	2.0	6700	48	5	HS2D-80	1/2	LE22	3	
F12.4 50	-	-	-	-	-	1.5	8400	60	5	HS2D-95	3/4	LE22	3	
F12.5 75	-	-	-	-	-	3.0	8400	60	7-1/2	HS2D-95	3/4	LE22	3	
F14.9 30	9800	70	0.5	9700	69	2.0	9000	64	3	HS2D-120	1	LE22	3	
F14 50	12300	88	0.5	11200	80	1.5	10500	75	5	HS2D-150	1	LE22	3	
F14.1 75	-	-	-	-	-	2.0	10500	75	7-1/2	HS2D-120	1	LE22	3	
F16.9 50	-	-	-	-	-	0.7	12600	90	5	HS2D-150	1	LE22	3	
F16.9 75	16800	120	-	-	-	-	-	-	7-1/2	HS2D-190	1-1/2	LE22	3	
F16 75	-	-	0.5	15400	110	1.6	12600	90	7-1/2	HS2D-150	1	LE22	3	
F16 100	18480	132	-	-	-	-	-	-	10	HS2D-190	1-1/2	LE22	3	
F16.1 100	-	-	0.5	16800	120	2.3	14700	105	10	HS2D-190	1-1/2	LE40	5	
F16.1 150	-	-	-	-	-	2.5	16800	120	15	HS2D-190	1-1/2	LE22	3	
F18.9 75	-	-	-	-	-	0.9	16800	120	7-1/2	HS2D-190	1-1/2	LE22	3	
F18.8 100	18200	130	-	-	-	-	-	-	10	HS2D-235	1-1/2	LE40	5	
F18.9 100	-	-	0.5	19200	137	-	-	-	10	HS2D-235	1-1/2	LE40	5	
F18.9 150	23100	165	-	-	-	-	-	-	15	HS2D-235	1-1/2	LE40	5	
F18 150	-	-	0.5	23100	165	3.0	21000	150	15	HS2D-235	1-1/2	LE40	5	
F18 200	24600	176	-	-	-	-	-	-	20	HS2D-275	2	LE40	5	
F18.1 200	-	-	0.5	25900	185	2.0	25200	180	20	HS2D-275	2	LE40	5	
F18.2 250	-	-	0.5	27300	195	4.0	25200	180	25	HS2D-275	2	LE40	5	
F18.1 300	30500	218	-	-	-	-	-	-	30	HS2D-345	2	LE40	5	
F18.2 300	-	-	0.5	30100	215	3.0	29400	210	30	HS2D-345	2	LE40	5	
F18.3 400	-	-	0.5	31500	225	6.0	29400	210	40	HS2D-345	2	LE40	5	
F20.9 400	-	-	-	-	-	5.0	29400	196	40	HS2D-345	2	LE40	5	
F20 400	-	-	-	-	-	5.0	34000	224	40	HS2D-345	2	LE55	7-1/2	

1
2
1
2
1
2
3
2
3
2
3

Fuel

Gas = G

Oil = O

Gas/Oil = GO

See 1-F-15.15
or 1-F-15.25
for Heavy Oil

- 1 Capacity based on an elevation of 2,000 feet. Capacity will be reduced 4% for each additional 1,000 feet of elevation.
- 2 Oil burners - No. 2 oil, GPH based upon 140,000 Btu/U.S. gallon. Maximum viscosity 38 SSU at 100°F average 31 Redwood seconds. Mechanical pressure, air or steam atomizing, gas pilot ignition standard. Spark ignition of No. 2 oil optional on burners under 60 GPH.
- 3 Standard motor voltage 240/480-60-3.

Dimensions

BASIC BURNER MODEL NO.	SHIPPING WEIGHT		OVERALL BURNER DIMENSIONS (INCHES)							
	LBS. APPROX.		A	B	C	D	E	F ₁	F ₂	G
F10 15	570									
F10.1 30	600									
F10 30	600		23-1/8	5	29-1/2	10	16-3/4	10-1/4	15	15-1/2
F10.2 50	620									
F10.1 50	620									
F12 30	650		23-1/8	5	30	12	17-5/8	10	15	15-1/2
F12.9 30	650									
F12.1 50	700		23-1/8	5	30	12	17-5/8	10-1/4	15	15-1/2
F12 50	700									
F12.4 50	800		31	6	37-1/2	12	21-1/4	13	19	18
F12.5 75	850									
F14.9 30	1000		32-7/8	7	37-1/2	14	21-1/4	14-3/4	19	19-1/2
F14 50	1000									
F14.1 75	1100									
F16.9 50	1300		32-7/8	7	37-1/2	16	21-1/4	14-3/4	19	19-1/2
F16 75	1300									
F16.9 75	1300									
F16.1 100	1400		34-1/8	8	39-1/2	16	21-1/4	14-3/4	19	19-1/2
F16 100	1400									
F16.1 150	1400									
F18.9 75	1400		34-1/8	8	39-1/2	18	21-1/2	14-3/4	19	19-1/2
F18.9 100	1500									
F18.8 100	1500									
F18 150	1600		34-1/8	8	39-1/2	18	21-1/2	14-3/4	19	19-1/2
F18.9 150	1600									
F18.1 200	1700									
F18 200	1700									
F18.2 250	1800		37-3/4	9	43	18	25-1/2	16-3/4	19	20-1/2
F18.2 300	1900									
F18.1 300	1900									
F18.3 400	2000									
F20.9 400	2500		37-3/4	9	43	20	25-1/2	16-3/4	19	20-1/2
F20 400	2500									
		4	5							

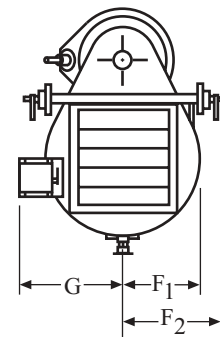
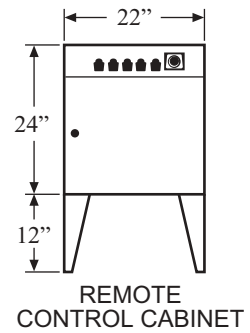

Fuel

Gas = G
Oil = O
Gas/Oil = GO

See 1-F-15.15
or 1-F-15.25
for Heavy Oil

4 Weight will vary by burner depending on size and type of gas train, type of fuel control system, etc. The figure shown represents a burner with standard controls including gas train.

5 Dimensions shown cover the most commonly used burners within each size. These dimensions are typical and subject to change without notice. Request a certified print for specific dimensions.

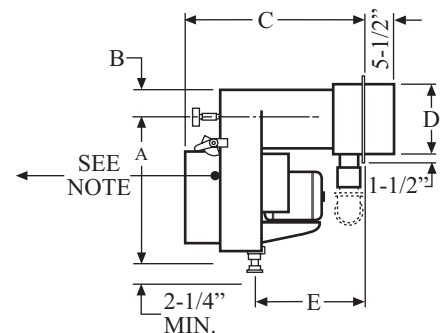

NOTE

Dimension C plus burner nose length (5-1/2" standard) is required behind the burner to remove the drawer assembly.

Standard Equipment

SINGLE OR COMBINATION FUEL BURNERS		FUEL CONTROL SYSTEMS							
DESCRIPTION		MODULATING OR HI-LOW PROVEN LOW FIRE START							
		GAS SYSTEM	OIL SYSTEMS			GAS-OIL SYSTEMS			
			E2	Pressure Atomizing	Air Atomizing	Steam Atomizing	E2F7.2	E2F8.2	E2F9.2
				F7.2	F8.2	F9.2			
GENERAL	Blower Motor and Fan Air Inlet Register Air Flow Safety Switch Proven Low Fire Start, Modulating Motor Air-Fuel Control Flame Detector (Scanner Type)	X	X	X	X	X	X	X	
CONTROL CABINET	Control Cabinet, 22" x 24", 4 Indicator Lights & Control Switch Programming Combustion Safety Control Motor Contactor and O. L. Protection Modulating Sub-Panel with Manual-Auto Switch, & Manual Potentiometer	X	X	X	X	X	X	X	
	Air Compressor Motor Contactor w/O. L. Protection			X		X			
	Oil Pump Motor Contactor w/O. L. Protection		X			X			
	Fuel Transfer Switch (Gas - Oil)					X	X	X	
GAS PILOT SYSTEM	Safety Pilot Burner or Ignitor Gas Pilot Ignition Transformer, 6000 V. Pilot Solenoid Valve Pilot Gas Pressure Regulator (Low Pressure Type) Pilot Shutoff Cock	X	X	X	X	X	X	X	
GAS CONTROL	Butterfly Gas Valve Safety Leak Test Cock Gas Pressure Gauge U. L. Gas Control Train (Not Included in Price of Burner)	X				X	X	X	
OIL CONTROLS	Oil Drawer Assembly with Air Diffuser Main Oil Solenoid Valve Secondary Safety Oil Solenoid Valve Low Oil Pressure Switch Manual Valve Oil Pressure Gauges Oil Metering Valve		X	X	X	X	X	X	
	Oil Strainer Burner Oil Pump Set Bypassing Oil Nozzle Check Valve (Return Line) Check Valve (Supply Line)		X			X			
	Air or Steam Atomizing Oil Nozzle Oil Pressure Regulator (except size 18 burners) Flexible Metal Hose Oil Supply Line			X	X		X	X	
AIR CONTROLS	Air Compressor Low Air Pressure Switch Back Pressure Regulating and Relief Valve Flexible Air Supply Line Air Pressure Regulating Valve Air Pressure Gauges Air Metering Valve Air Check Valve			X			X		
STEAM CONTROLS	Manual Valve Low Atomizing Steam Pressure Switch Steam Strainer Steam Regulator Steam Metering Valve Steam Trap Steam Solenoid Valve Steam Check Valve Condensate Manual Valve Flexible Metal Hose Steam Supply Line				X			X	

Optional Equipment