

Specification Data

1	R	15.1	Rev. 22
1-03	Replaces	5-01	

TYPE R TURBO RING FORCED DRAFT BURNERS

Patented*

USING GAS AND LIGHT OIL-MECHANICAL PRESSURE ATOMIZATION

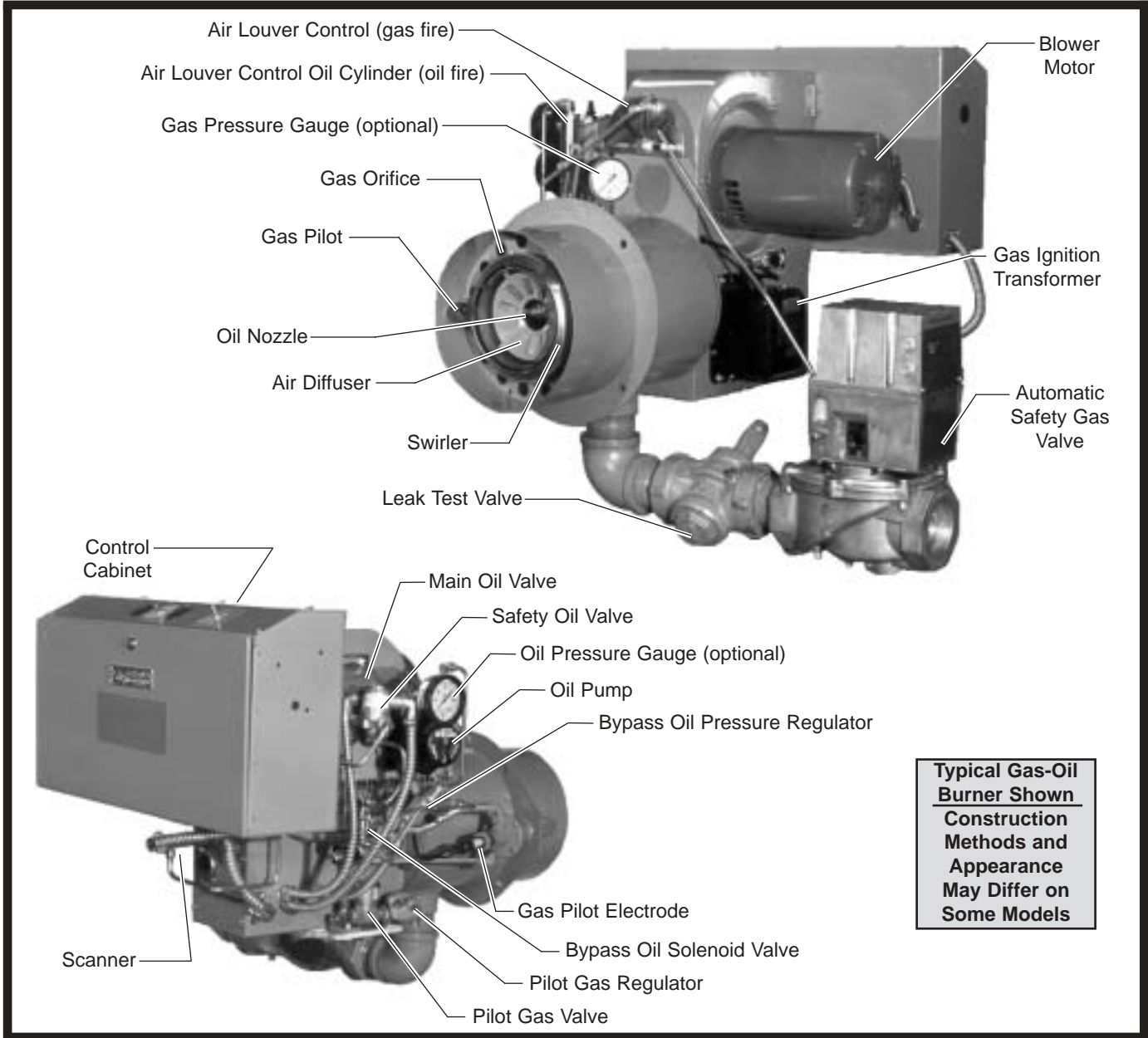

Burner Numbering System

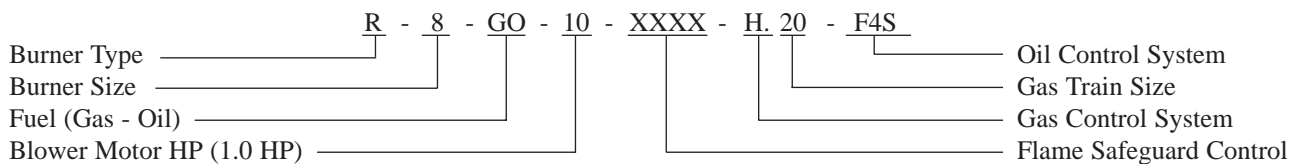

1 See Catalog Sheet 1-gen-10.1 for burner numbering.

2 Use Order Entry and Equipment Pricing Form 1196 when placing order.

*Covered by one or more of the following patents:
U.S. patent numbers 4785680; 4932274; 5441404;
5722821; 5944506; 5957682. Canadian patent
number 1279632 and Canadian patents pending.

Specifications and Capacities

BASIC BURNER MODEL NO.	MAXIMUM FIRING RATE									BURNER BLOWER MOTOR	
	COMBUSTION CHAMBER PRESSURE										
	DRAFT-.05" W.C.			LOW PRESSURE			HIGH PRESSURE				
	NATURAL GAS	NO. 2 OIL	PRESS.	NATURAL GAS	NO.2 OIL	PRESS.	NATURAL GAS	NO. 2 OIL			
	BTU/HR 1000s	GPH	INCHES W.C.	BTU/HR 1000s	GPH	INCHES W.C.	BTU/HR 1000s	GPH	3450 RPM	VOLTAGE	HP
R6.9 03	630	4.5	0.2	560	4.0	----	----	----	120/60/1	1/3	
R6 03	910	6.5		840	6.0						
R6.1 03	1120	8.0		990	7.0						
R6.2 03	1190	8.5	0.3	1120	8.0						
R6.3 05	----	----	0.4	1190	8.5					1/2	
R8 05	2100	15.0	0.2	1960	14.0					3/4	
R8.1 07	2250	16.0		2100	15.0						
R8.2 10	2380	17.0	0.3	2100	15.0	----			240/60/1	1	
R8.3 15	2800	20.0		2520	18.0					1½	
R8.4 20	----	----		2800	20.0	1.0	2030	14.5	240/60/3	2	
R10.9 10	2800	20.0	----	----	----	----	----	----	240/60/1	1	
R10 15	3650	26.0		3200	22.8					1½	
R10 20	4200	30.0	0.2	3800	27.1	1.0	2800	20.0		2	
R10.1 30	4500	32.0		4200	30.0		3080	22.0		3	
R10.2 50	6300	45.0	0.6	5700	41.0		5600	40.0	240/60/3	5	
R12.9 30	6000	43.0		5700	41.0		5450	39.0		3	
R12.9 50	6000	43.0		5700	41.0		5450	39.0		5	
R12 30	6400	46.0		6300	45.0	.75	6000	43.0		3	
R12 50	7100	51.0	0.3	6900	49.0		6700	48.0		5	
R12.1 50	8100	58.0		7800	55.7		7550	54.0			

Fuel

Gas = G
 Oil = O
 Gas/Oil = GO

- 1** Capacity based on an elevation of 2,000 feet. Capacity will be reduced 4% for each additional 1,000 feet of elevation.
- 2** Oil burners - No. 2 oil, GPH based upon 140,000 BTU/U.S. gallon. Maximum viscosity 38 SSU at 100°F average 31 Redwood seconds. Mechanical pressure atomization.
- 3** Oil burners supplied with burner mounted oil pump as standard except for R12-50 and R12.1-50. Modulating burners with burner mounted pumps limited to 35.0 GPH with 3.0 HP blower motor and 45.0 GPH with 5.0 HP blower motor. See catalog Sheet 6-10-2.2 for further data on burner high pressure pump sets.

Dimensions

BASIC BURNER MODEL NO.	SHIPPING WEIGHT LBS. APPROX.	OVERALL BURNER DIMENSIONS (INCHES)											
		A	B	C	D	E	F	G	H	I	J	K	L
		R6.9 03	160	6	19	12-1/8	6	14-1/4	26	11-5/8	11-7/8	9	8-1/8
R6 03	165												
R6.1 03													
R6.2 03													
R6.3 05													
R8 05													
R8.1 07	230												
R8.2 10	250									12		6-5/16	
R8.3 15	270	6-1/2	19-3/4	13-3/4	8	13-7/16	28-1/2	13-1/2	14-1/2				
R8.4 20	280												
R10.9 10	300												
R10 15	320				10					14			3
R10 20	360												
R10.1 30	410												
R10.2 50	430					14-9/16	30-1/4		16	16			4-1/4
R12.9 30	650	8-1/2	21-1/8	15-3/8	12	15-3/16	30-1/4				8-11/16	6-1/2	5-1/4
R12.9 50													
R12 30													
R12 50	700								16	SEE NOTE			
R12.1 50													
		4	5										

Fuel

Gas = G
 Oil = O
 Gas/Oil = GO

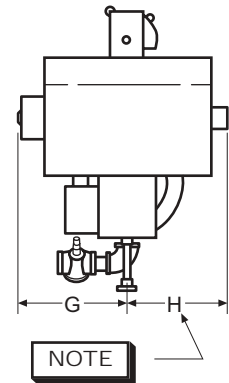
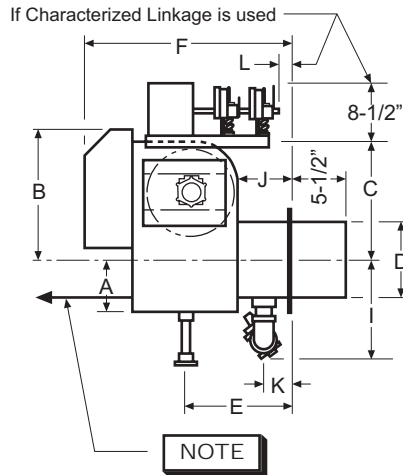

4 Weight will vary by burner depending on size and type of gas train, type of fuel control system, etc. The figures shown represent a burner with standard controls including gas train and burner oil pump set where applicable.

5 The dimensions shown are typical and subject to change without notice. For specific dimensions, request a certified print.

Standard Equipment

SINGLE OR COMBINATION FUEL BURNERS		1 FUEL CONTROL SYSTEMS											
		ON - OFF FIXED AIR & FUEL			ON-OFF OR HI-LOW LOW FIRE START			MODULATING PROVEN LOW FIRE START			MODULATING PROVEN LOW FIRE START		
		GAS	OIL	GAS-OIL	GAS	OIL	GAS-OIL	GAS	OIL	GAS-OIL	GAS	OIL	GAS-OIL
		B	F1	B - F1	H	F4H	H-F4H	E2	F6R.2	E2-F6R.2	E2	F7.2	E2-F7.2
DESCRIPTION													
GENERAL	Blower Motor and Fan Air Inlet Register and Air Inlet Guard Flame Detector (UV Scanner)	X	X	X	X	X	X	X	X	X	X	X	
	Air Flow Safety Switch (also on Oil Burners when required)	X		X	X		X	X		X		X	
CONTROL CABINET	Combustion Flame Safeguard Control On - Off Switch Motor Contactor or Starter (½ HP and larger)	X	X	X	X	X	X	X	X	X	X	X	
	Fuel Transfer Switch			X			X			X		X	
	Modulating Sub-Panel with Manual-Auto Switch and Manual Potentiometer							X	X	X	X	X	
	Two Indicator Lights	X	X	X	X	X	X						
	Four Indicator Lights							X	X	X	X	X	
AIR-FUEL CONTROL	Fixed Air and Fuel	X	X	X									
	Low Fire Start, Motorized Gas Valve Air-Fuel Control				X		X						
	Low Fire Start, Oil Valving and Oil Cylinder Air-Fuel Control					X	X						
	Proven Low Fire Start, Modulating Motor Air-Fuel Control							X	X	X	X	X	
GAS CONTROL	Safety Pilot Burner Ignition Transformer, 6000 Volt Pilot Solenoid Valve Pilot Shut-Off Cock Safety Test Cock Gas Orifices	X		X	X		X	X		X	X	X	
	Oil Drawer Assembly with Air Diffuser Main Oil Solenoid Valve Safety Oil Solenoid Valve Low Oil Pressure Switch (When Required) Ignition Transformer, 10,000 Volts 2 Gas Pilot Ignition 3 Oil Pump		X	X		X	X		X	X		X	
	Simplex Oil Nozzle(s)		X	X		X	X		X	X			
	By-Passing Oil Nozzle(s) Strainer Spring Loaded Check Valve										X	X	
	By-Pass Oil Solenoid Valve By-Pass and 3-Way Solenoid Valve By-Pass Pressure Regulating Valve Oil Cylinder Assembly					X	X						
OIL CONTROL	Oil Metering Valve							X	X		X	X	

1 Natural gas and/or No. 2 oil.

2 Spark ignition of oil standard on STRAIGHT OIL burners under 34 GPH.

3 Proven gas pilot ignition is standard on all GAS and COMBINATION GAS/OIL burners and also for all sizes 12 OIL Burners.

Optional Equipment

■ Characterized Linkage available on sizes 10 and 12 Burners with Modulating Systems.
